



Features

- Interdigitated amplifying gates
- Fast turn-on and high di/dt
- Low switching losses

Typical Applications

- Inductive heating
- Electronic welders
- Self-commutated inverters

Part No. Y38KKE-KT33cT

I_{T(AV)}	820A
V_{DRM}, V_{RRM}	800V 1000V
	1200V 1400V
	1600V 1800V
t_q	18~50μs

SYMBOL	CHARACTERISTIC	TEST CONDITIONS	T _J (°C)	VALUE			UNIT
				Min	Type	Max	
I _{T(AV)}	Mean on-state current	180° half sine wave 50Hz Double side cooled, T _C =55°C	125			820	A
V _{DRM} V _{RRM}	Repetitive peak off-state voltage Repetitive peak reverse voltage	tp=10ms	125	800		1800	V
I _{DRM} I _{RRM}	Repetitive peak current	at V _{DRM} at V _{RRM}	125			40	mA
I _{TSM}	Surge on-state current	10ms half sine wave	125			9.0	kA
I ² t	I ² t for fusing coordination	V _R =0.6V _{RRM}				405	A ² s*10 ³
V _{TO}	Threshold voltage		125			1.36	V
r _T	On-state slope resistance					0.53	mΩ
V _{TM}	Peak on-state voltage	I _{TM} =1500A, F=15kN	25			3.15	V
dv/dt	Critical rate of rise of off-state voltage	V _{DM} =0.67V _{DRM}	125			1000	V/μs
di/dt	Critical rate of rise of on-state current	V _{DM} = 67%V _{DRM} to 1000A, Gate pulse t _r ≤0.5μs I _{GM} =1.5A Single pulse	125			1200	A/μs
Q _{rr}	Recovery charge	I _{TM} =1000A, tp=4000μs, di/dt=-20A/μs, V _R =100V	125		460		μC
t _q	Circuit commutated turn-off time	I _{TM} =1000A, tp=4000μs, V _R =100V dv/dt=30V/μs, di/dt=-20A/μs	125	18		50	μs
I _{GT}	Gate trigger current	V _A =12V, I _A =1A	25	40		250	mA
V _{GT}	Gate trigger voltage			0.9		2.5	V
I _H	Holding current			20		400	mA
I _L	Latching current					500	mA
V _{GD}	Non-trigger gate voltage	V _{DM} =67%V _{DRM}	125			0.3	V
R _{th(j-c)}	Thermal resistance Junction to case	At 180° sine double side cooled Clamping force 15kN				0.035	°C /W
R _{th(c-h)}	Thermal resistance case to heat sink					0.008	
F _m	Mounting force			10		20	kN
T _{vj}	Junction temperature			-40		125	°C
T _{stg}	Stored temperature			-40		140	°C
W _t	Weight				250		g
Outline	KT33cT						

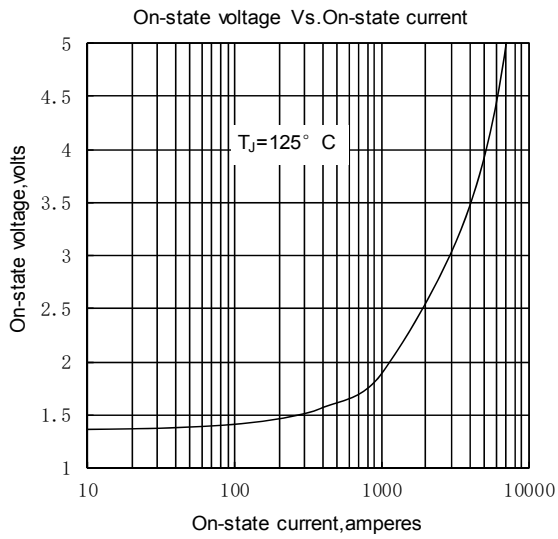

Fig. 1

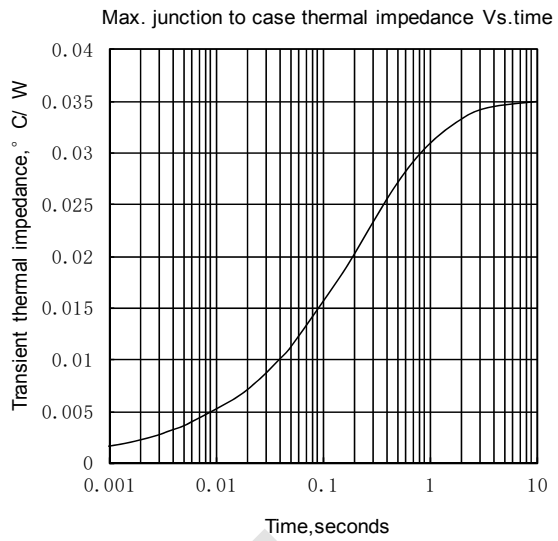

Fig. 2

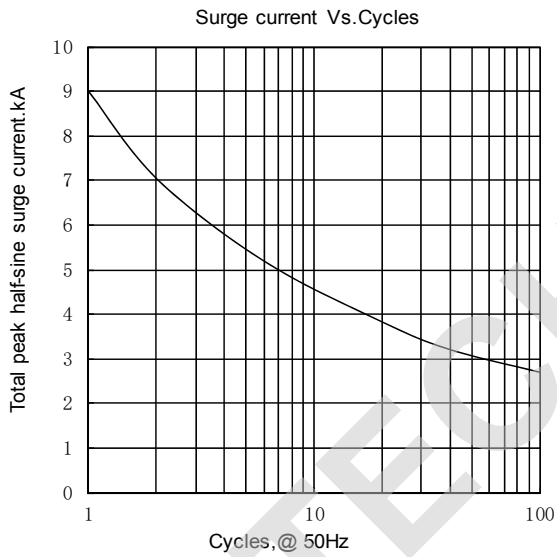

Fig. 3

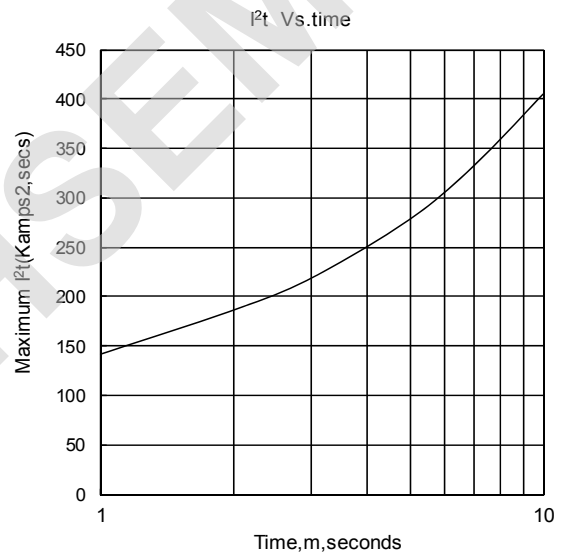

Fig. 4

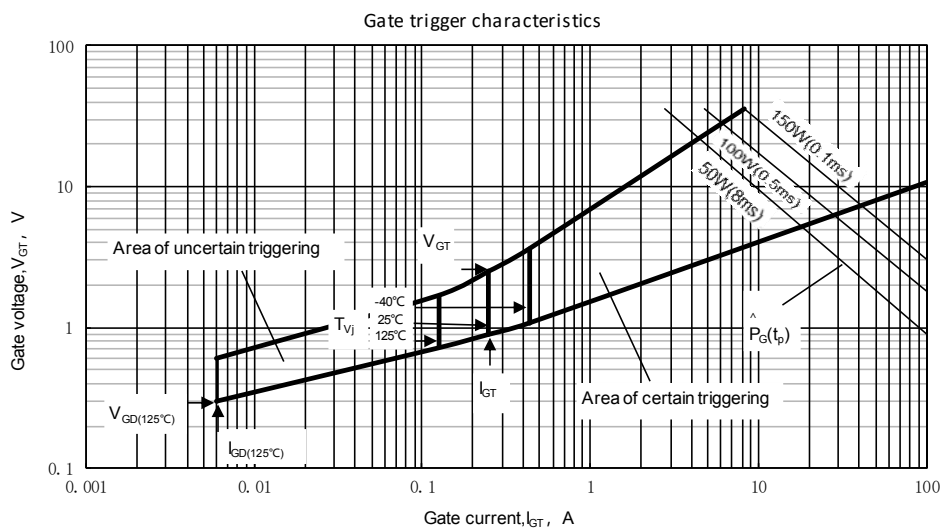
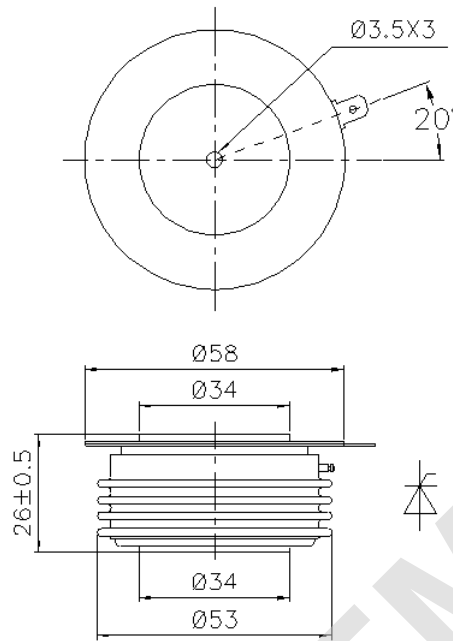

Fig.5

Outline:



TECHSEM reserves the right to change specifications without notice.

TECHSEM