

**Features**

- Interdigitated amplifying gates
- Fast turn-on and high di/dt
- Low switching losses

**Typical Applications**

- Inductive heating
- Electronic welders
- Self-commutated inverters

**Part No. Y50KKE-KT50cT**

<b>I<sub>T(AV)</sub></b>	<b>1330A</b>
<b>V<sub>DRM</sub>, V<sub>RRM</sub></b>	<b>800V 1000V</b>
	<b>1200V 1400V</b>
	<b>1600V 1800V</b>
<b>t<sub>q</sub></b>	<b>18~50μs</b>

SYMBOL	CHARACTERISTIC	TEST CONDITIONS	T <sub>j</sub> (°C)	VALUE			UNIT
				Min	Type	Max	
I <sub>T(AV)</sub>	Mean on-state current	180° half sine wave 50Hz Double side cooled, T <sub>C</sub> =55°C	125			1330	A
V <sub>DRM</sub> V <sub>RRM</sub>	Repetitive peak off-state voltage Repetitive peak reverse voltage	tp=10ms	125	800		1800	V
I <sub>DRM</sub> I <sub>RRM</sub>	Repetitive peak current	at V <sub>DRM</sub> at V <sub>RRM</sub>	125			80	mA
I <sub>TSM</sub>	Surge on-state current	10ms half sine wave	125			14	kA
I <sup>2</sup> t	I <sup>2</sup> t for fusing coordination	V <sub>R</sub> =0.6V <sub>RRM</sub>				980	A <sup>2</sup> s*10 <sup>3</sup>
V <sub>TO</sub>	Threshold voltage		125			1.56	V
r <sub>T</sub>	On-state slope resistance					0.33	mΩ
V <sub>TM</sub>	Peak on-state voltage	I <sub>TM</sub> =3000A, F=24kN	25			3.15	V
dv/dt	Critical rate of rise of off-state voltage	V <sub>DM</sub> =0.67V <sub>DRM</sub>	125			1000	V/μs
di/dt	Critical rate of rise of on-state current	V <sub>DM</sub> = 67%V <sub>DRM</sub> to 1600A, Gate pulse t <sub>r</sub> ≤0.5μs I <sub>GM</sub> =1.5A Single pulse	125			1200	A/μs
Q <sub>rr</sub>	Recovery charge	I <sub>TM</sub> =1000A, tp=4000μs, di/dt=-20A/μs, V <sub>R</sub> =100V	125		750		μC
t <sub>q</sub>	Circuit commutated turn-off time	I <sub>TM</sub> =1000A, tp=4000μs, V <sub>R</sub> =100V dv/dt=30V/μs, di/dt=-20A/μs	125	18		50	μs
I <sub>GT</sub>	Gate trigger current	V <sub>A</sub> =12V, I <sub>A</sub> =1A	25	40		300	mA
V <sub>GT</sub>	Gate trigger voltage			0.9		3.0	V
I <sub>H</sub>	Holding current			20		500	mA
I <sub>L</sub>	Latching current					500	mA
V <sub>GD</sub>	Non-trigger gate voltage	V <sub>DM</sub> =67%V <sub>DRM</sub>	125			0.3	V
R <sub>th(j-c)</sub>	Thermal resistance Junction to case	At 180° sine double side cooled Clamping force 24kN				0.020	°C /W
R <sub>th(c-h)</sub>	Thermal resistance case to heat sink					0.005	
F <sub>m</sub>	Mounting force			19		26	kN
T <sub>vj</sub>	Junction temperature			-40		125	°C
T <sub>stg</sub>	Stored temperature			-40		130	°C
W <sub>i</sub>	Weight					440	g
Outline	KT50cT						

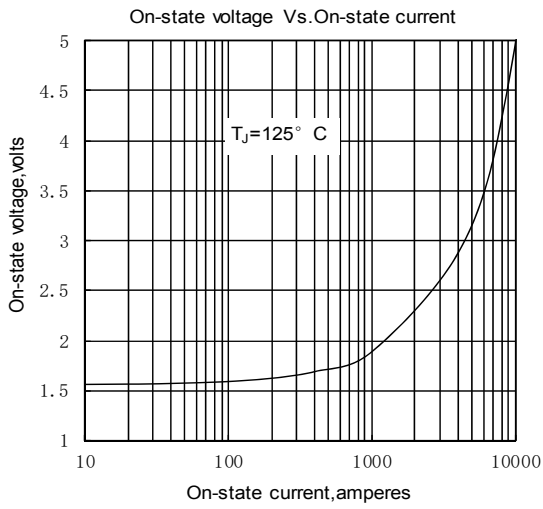

Fig. 1

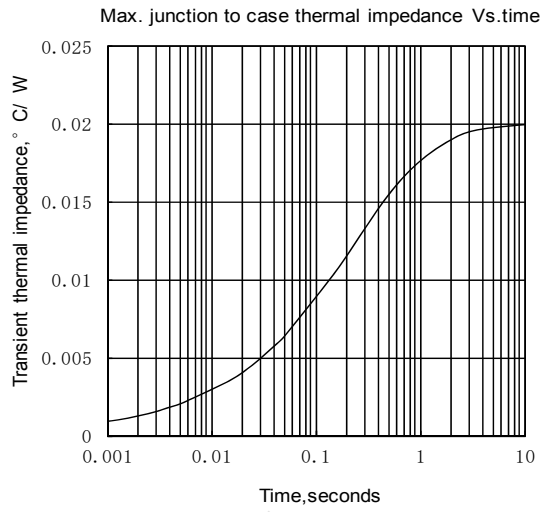

Fig. 2

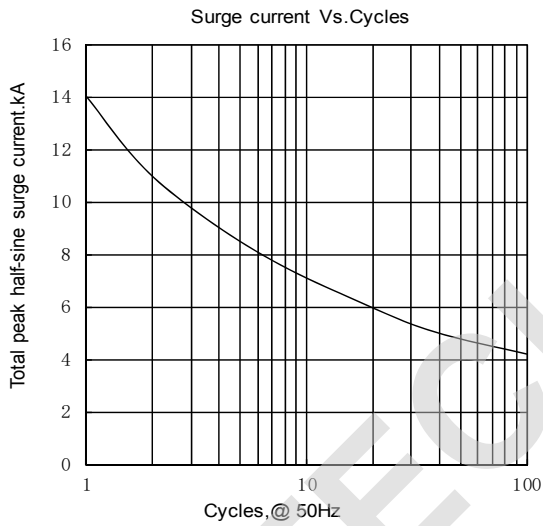

Fig. 3

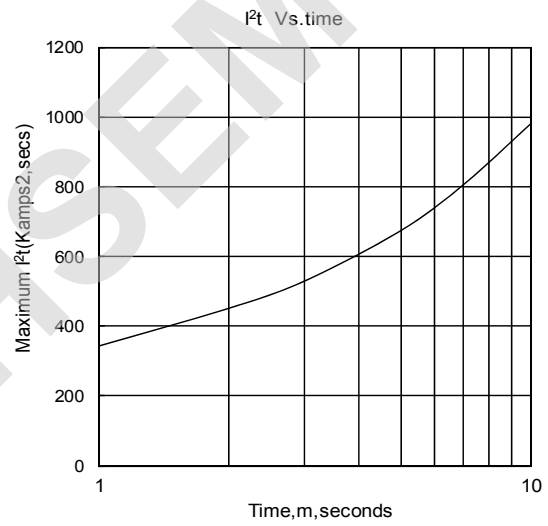

Fig. 4

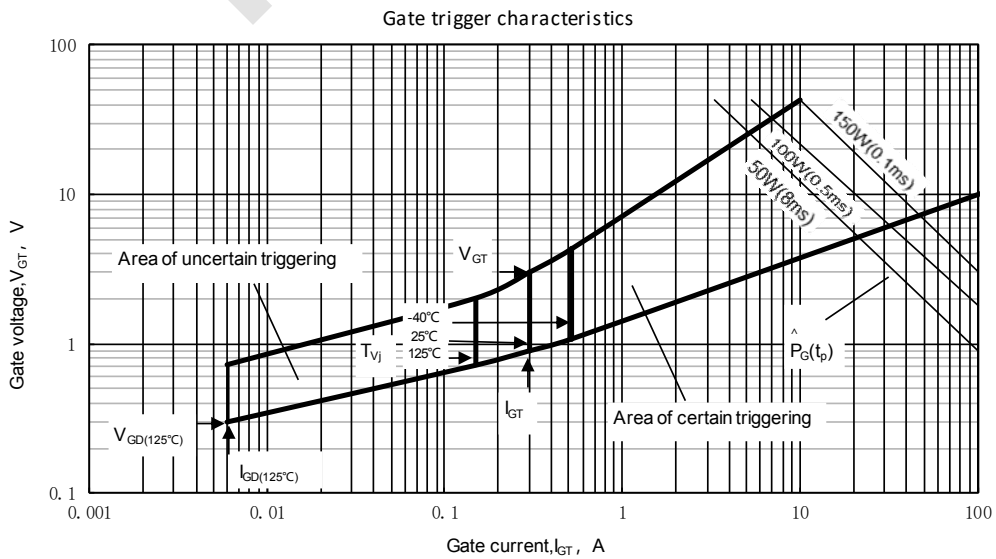
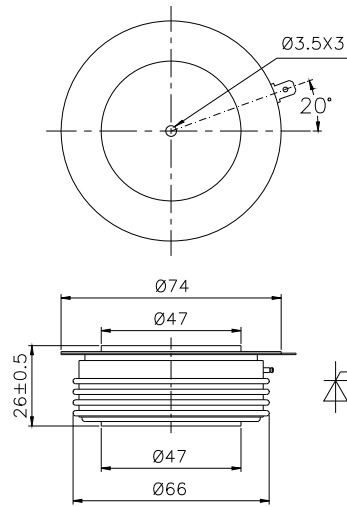

Fig.5

Outline:



TECHSEM reserves the right to change specifications without notice.

TECHSEM