

Features:

- Interdigitated amplifying gates
- Fast turn-on and high di/dt
- Low switching losses
- Short turn-off time
- Hermetic metal cases with ceramic insulators

Typical Applications

- Inductive heating
- Electronic welders
- Self-commutated inverters
- AC motor speed control

Part No. Y45KAB-KT44cT

I_{T(AV)}	1210A
V_{DRM}, V_{RRM}	600V 800V
t_q	6~15μs

SYMBOL	CHARACTERISTIC	TEST CONDITIONS	T _j (°C)	VALUE			UNIT
				Min	Type	Max	
I _{T(AV)}	Mean on-state current	180° half sine wave 50Hz Double side cooled,	T _c =55°C	125		1210	A
V _{DRM} V _{RRM}	Repetitive peak off-state voltage Repetitive peak reverse voltage	tp=10ms	125	600		900	V
I _{DRM} I _{RRM}	Repetitive peak off-state current Repetitive peak reverse current	at V _{DRM} at V _{RRM}	125			60	mA
I _{TSM}	Surge on-state current	10ms half sine wave	125			9.6	kA
I ² t	I ² t for fusing coordination	V _R =0.6V _{RRM}	125			461	A ² s*10 ³
V _{TO}	Threshold voltage		125			1.44	V
r _T	On-state slope resistance		125			0.33	mΩ
V _{TM}	Peak on-state voltage	I _{TM} =2400A, F=21kN	25			3.20	V
dv/dt	Critical rate of rise of off-state voltage	V _{DM} =0.67V _{DRM}	125			1000	V/μs
di/dt	Critical rate of rise of on-state current	V _{DM} = 67%V _{DRM} to 2000A, Gate pulse t _r ≤0.5μs I _{GM} =1.5A	125			1500	A/μs
Q _{rr}	Recovery charge	I _{TM} =1000A, tp=4000μs, di/dt=-20A/μs, V _R =100V	125		83	100	μC
t _q	Circuit commutated turn-off time	I _{TM} =1000A, tp=4000μs, V _R =100V dv/dt=30V/μs, di/dt=-20A/μs	125	6		15	μs
I _{GT}	Gate trigger current	V _A =12V, I _A =1A	25	30		250	mA
V _{GT}	Gate trigger voltage			0.8		3.0	V
I _H	Holding current			20		400	mA
I _L	Latching current					500	mA
V _{GD}	Non-trigger gate voltage	V _{DM} =67%V _{DRM}	125			0.3	V
R _{th(j-c)}	Thermal resistance Junction to case	At 180° sine double side cooled Clamping force 21kN				0.024	°C /W
R _{th(c-h)}	Thermal resistance case to heat sink					0.006	
F _m	Mounting force			18		25	kN
T _{vj}	Junction temperature			-40		125	°C
T _{stg}	Stored temperature			-40		140	°C
W _i	Weight				400		g
Outline	KT44cT						

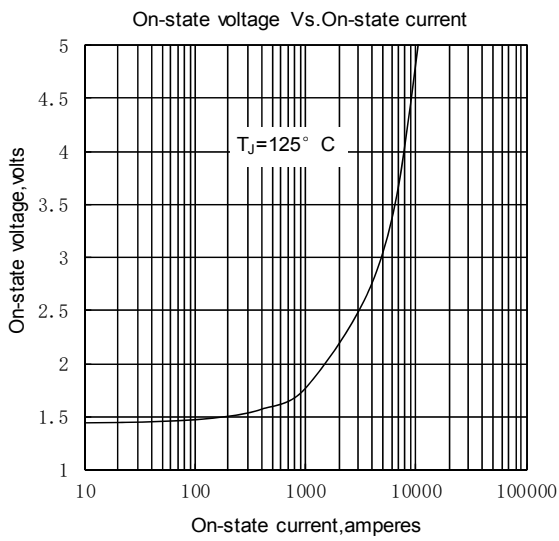

Fig. 1

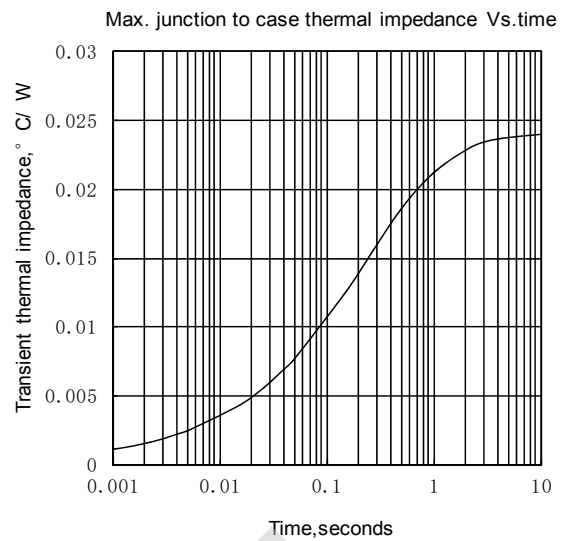

Fig. 2

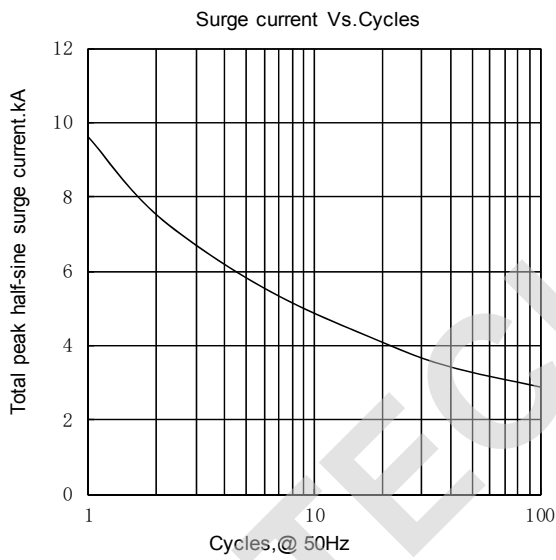

Fig. 3

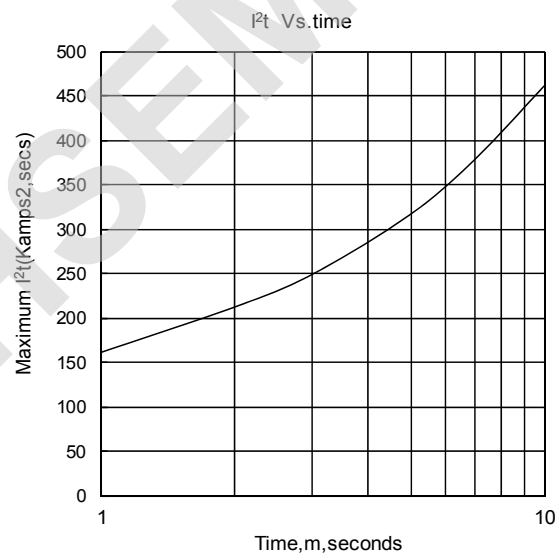

Fig. 4

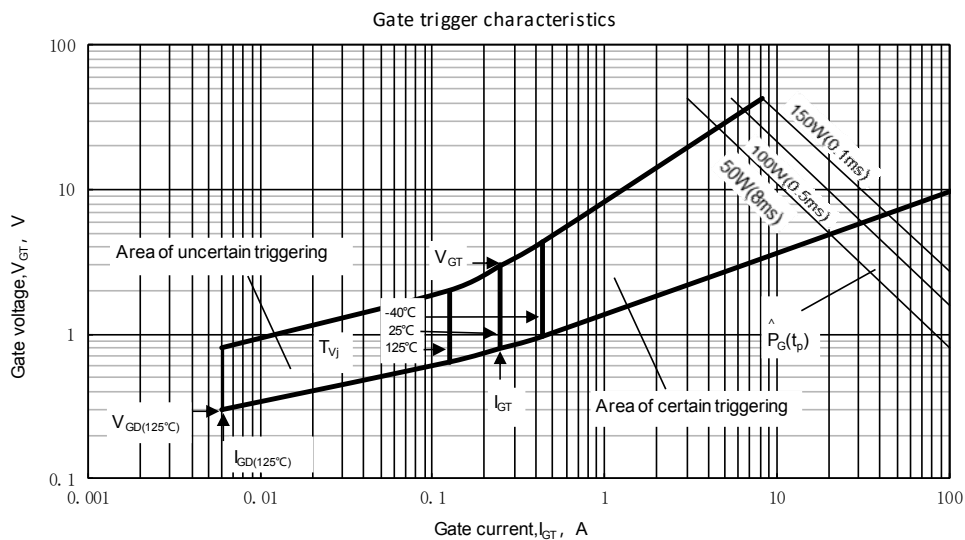
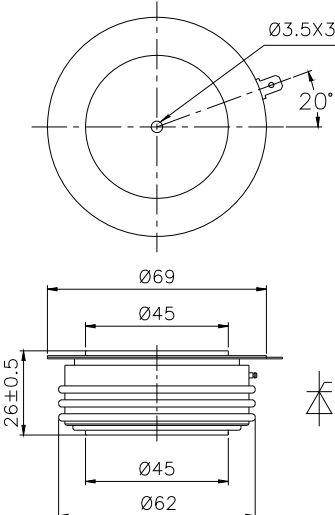

Fig.5

Outline:



TECHSEM reserves the right to change specifications without notice.

