

**Features**

- Optimized for high current rectifiers
- Very low threshold voltage and slop resistance
- Very low thermal resistance

**Typical Applications**

- High current application For Welders up to 5000Hz
- Electrode plating

<b>Part No. Y50ZKA-ZT44T</b>		
<b>I<sub>F(AV)</sub></b>	<b>5000A</b>	
<b>V<sub>RRM</sub></b>	<b>200V</b>	<b>400V</b>

SYMBOL	CHARACTERISTIC	TEST CONDITIONS	T <sub>j</sub> (°C)	VALUE			UNIT
				Min	Type	Max	
I <sub>F(AV)</sub>	Mean forward current	180° half sine wave 50Hz Double side cooled, T <sub>c</sub> =85°C	175			5000	A
V <sub>RRM</sub>	Repetitive peak reverse voltage	tp=10ms	175	200		400	V
I <sub>RRM</sub>	Repetitive peak current	at V <sub>RRM</sub>	175			50	mA
I <sub>FSM</sub>	Surge forward current	10ms half sine wave	175			45	kA
I <sup>2</sup> t	I <sup>2</sup> T for fusing coordination	V <sub>R</sub> =0V <sub>RRM</sub>					10000
V <sub>FO</sub>	Threshold voltage	I <sub>FM</sub> =5000~15000A	175			0.80	V
r <sub>F</sub>	Forward slop resistance						0.040
V <sub>FM</sub>	Max Peak on-state voltage	I <sub>FM</sub> =5000A, F=30kN	25			1.05	V
t <sub>rr</sub>	Reverse recovery time	I <sub>FM</sub> =2000A, tp=4000μs, di/dt=-60A/μs, V <sub>R</sub> =100V	175			4	μs
Q <sub>rr</sub>	Recovery charge						200
R <sub>th(j-c)</sub>	Thermal resistance Junction to case	At 180° sine double side cooled Clamping force 30.0kN				0.010	°C /W
R <sub>th(c-h)</sub>	Thermal resistance case to heat sink					0.005	
F <sub>m</sub>	Mounting force			20	30	40	kN
T <sub>vj</sub>	Junction temperature			-40		175	°C
T <sub>stg</sub>	Stored temperature			-40		175	°C
W <sub>t</sub>	Weight				150		g
Outline	ZT44T						

**Outline:**

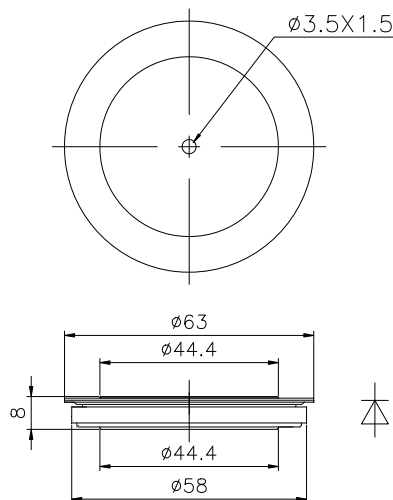

TECHSEM reserves the right to change specifications without notice.