



**Features**

- Optimized for high current rectifiers
- Very low threshold voltage and slop resistance
- Very low thermal resistance

**Typical Applications**

- High current application For Welders up to 2000Hz
- Electrode plating

<b>Part No. Y53ZPA-B-Z47T</b>			
<b>I<sub>F(AV)</sub></b>	<b>9200A</b>		
<b>V<sub>RRM</sub></b>	<b>200V</b>	<b>400V</b>	

SYMBOL	CHARACTERISTIC	TEST CONDITIONS	T <sub>J</sub> (°C)	VALUE			UNIT
				Min	Type	Max	
I <sub>F(AV)</sub>	Mean forward current	180° half sine wave 50Hz Double side cooled. T <sub>C</sub> =85°C	175			9200	A
V <sub>RRM</sub>	Repetitive peak reverse voltage	tp=10ms	175	200		400	V
I <sub>RRM</sub>	Repetitive peak current	at V <sub>RRM</sub>	175			50	mA
I <sub>FSM</sub>	Surge forward current	10ms half sine wave	175			60	kA
I <sup>2</sup> t	I <sup>2</sup> T for fusing coordination	V <sub>R</sub> =0V <sub>RRM</sub>				17049	10 <sup>3</sup> A <sup>2</sup> s
V <sub>FO</sub>	Threshold voltage	I <sub>FM</sub> =7000-21000A	175			0.78	V
r <sub>F</sub>	Forward slop resistance					0.031	mΩ
V <sub>FM</sub>	Max Peak on-state voltage	I <sub>FM</sub> =6000A	25			1.00	V
Q <sub>rr</sub>	Recovery charge	I <sub>FM</sub> =2000A, tp=4000μs, di/dt=-20A/μs, V <sub>R</sub> =100V	175			300	μC
R <sub>th(j-c)</sub>	Thermal resistance Junction to case	At 180° sine double side cooled				0.006	°C/W
R <sub>th(c-h)</sub>	Thermal resistance case to heat sink					0.003	
F <sub>m</sub>	Mounting force			30		50	kN
T <sub>vj</sub>	Junction temperature			-40		175	°C
T <sub>stg</sub>	Stored temperature			-40		175	°C
W <sub>t</sub>	Weight				100		g
Outline	Z47T						

**Outline:**

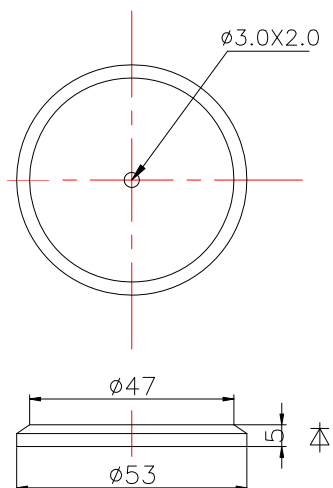

TECHSEM reserves the right to change specifications without notice.