

**Features:**

- Non-isolated. Mounting base as common anode cathode terminal.
- Pressure contact technology with increased power cycling capability
- Low forward voltage drop

**Typical Applications:**

- Welding Power Supply.
- Various Dc power supplies.

V <sub>RRM</sub>	Type & Outline
800V	MDx50-08-213F4
1000V	MDx50-10-213F4
1200V	MDx50-12-213F4
1400V	MDx50-14-213F4
1600V	MDx50-16-213F4
1800V	MDx50-18-213F4

MDx stands for any type of MDG, MDY

SYMBOL	CHARACTERISTIC	TEST CONDITIONS	T <sub>j</sub> (°C)	VALUE			UNIT
				Min	Type	Max	
I <sub>F(AV)</sub>	Mean forward current	180° half sine wave 50Hz Single side cooled, T <sub>c</sub> =100°C	150			50	A
I <sub>F(RMS)</sub>	RMS forward current					78	A
I <sub>RRM</sub>	Repetitive peak current	at V <sub>RRM</sub>	150			8	mA
I <sub>FSM</sub>	Surge forward current	V <sub>R</sub> =60%V <sub>RRM</sub> , t=10ms half sine	150			1.4	kA
I <sup>2</sup> t	I <sup>2</sup> t for fusing coordination					9.8	10 <sup>3</sup> A <sup>2</sup> s
V <sub>FO</sub>	Threshold voltage		150			0.80	V
r <sub>F</sub>	Forward slope resistance					4.78	mΩ
V <sub>FM</sub>	Peak forward voltage	I <sub>FM</sub> =150A	25			1.60	V
R <sub>th(j-c)</sub>	Thermal resistance Junction to case	At 180° sine. Single side cooled				0.70	°C/W
R <sub>th(c-h)</sub>	Thermal resistance case to heatsink	At 180° sine. Single side cooled				0.10	°C/W
F <sub>m</sub>	Terminal connection torque(M6)			4.5		6.0	N·m
	Mounting torque(M6)			4.5		6.0	N·m
T <sub>vj</sub>	Junction temperature			-40		150	°C
T <sub>stg</sub>	Stored temperature			-40		125	°C
W <sub>t</sub>	Weight				280		g
Outline	213F4						

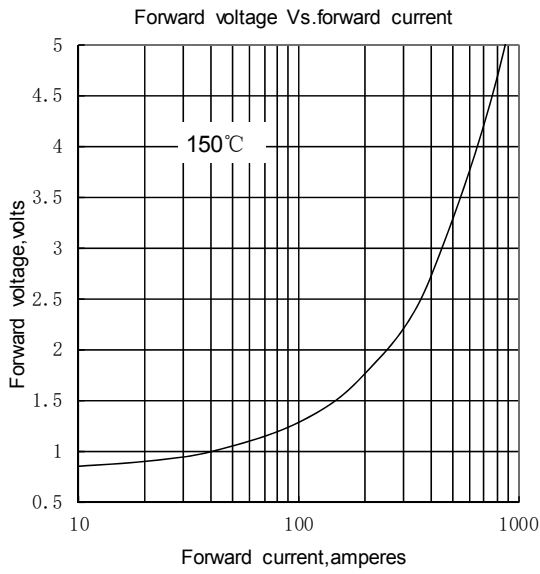

Fig.1

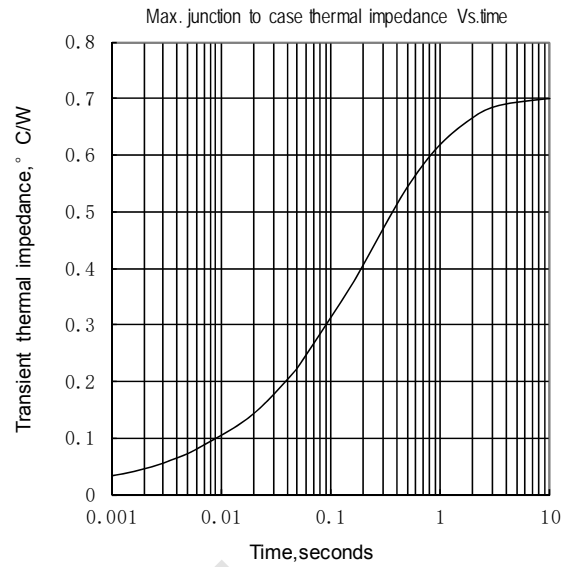

Fig.2

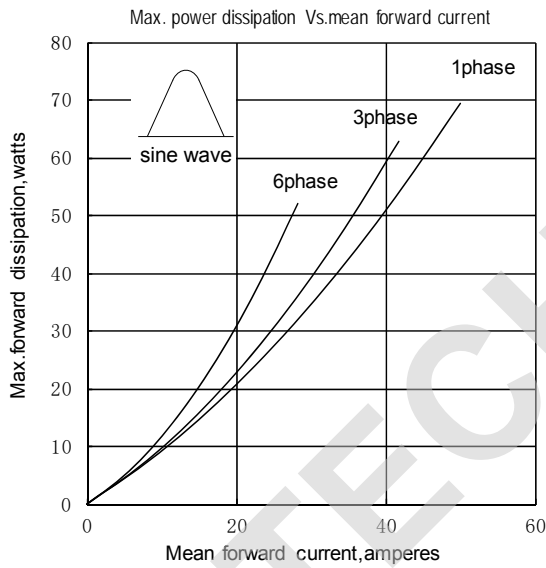

Fig.3

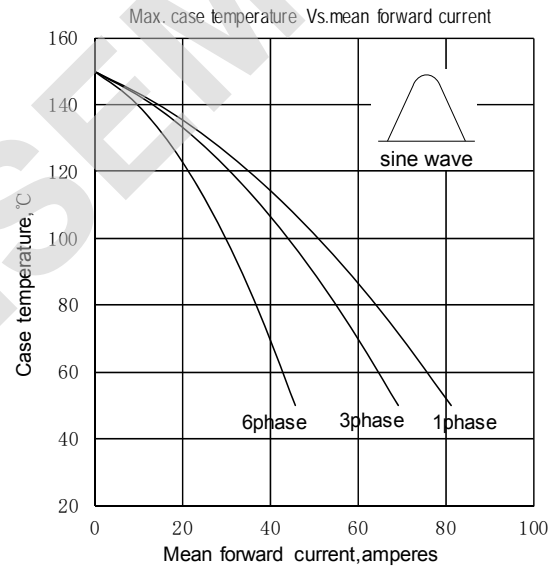

Fig.4

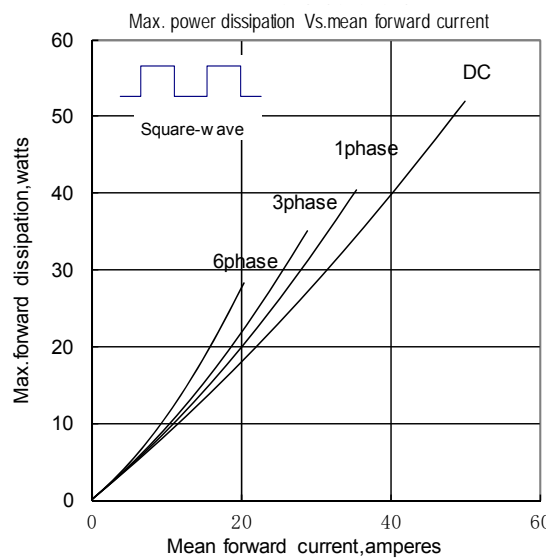

Fig.5

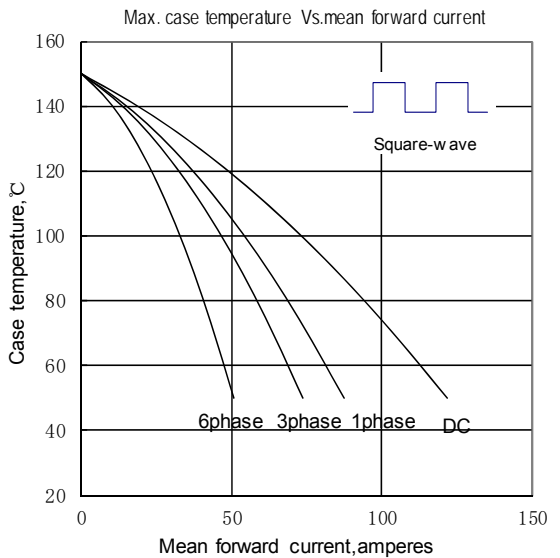

Fig.6

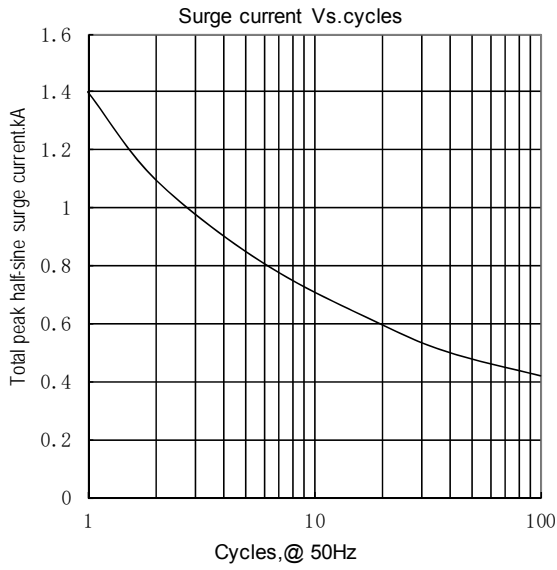

Fig.7

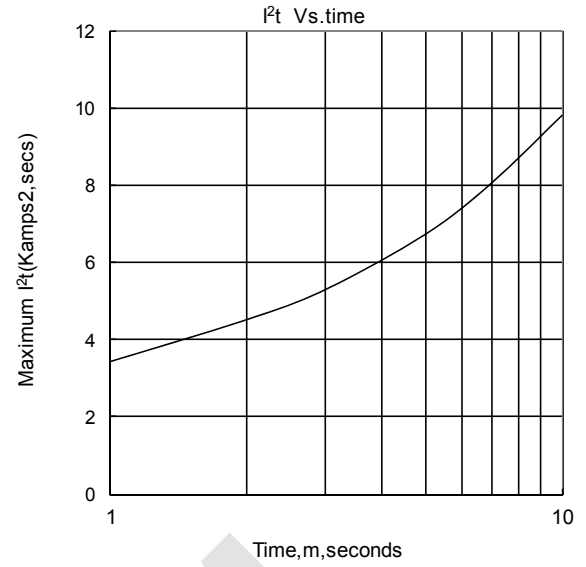
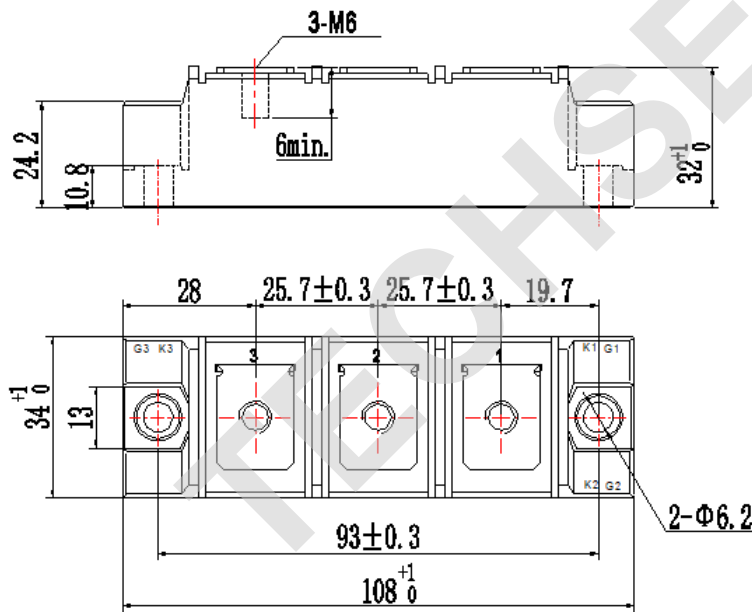
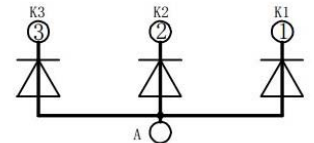

Fig.8

Outline:



MDG



MDY

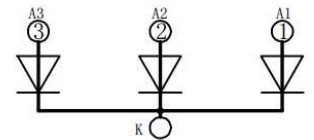

Unmarked dimensional tolerance: ±0.5mm