**Features**

- Low forward voltage drop
- High reverse voltage
- Hermetic metal cases with ceramic insulators

Typical Applications

- All purpose high power rectifier diodes
- High power resistance welding equipment
- Non-controllable and half-controllable rectifiers
- Controlled rectifiers

Part No. Y35ZPC-ZT33cT

I_{F(AV)}	1290A	
V_{RRM}	1200V	1400V
	1600V	1800V
	2000V	

SYMBOL	CHARACTERISTIC	TEST CONDITIONS	T _j (°C)	VALUE			UNIT
				Min	Type	Max	
I _{F(AV)}	Mean forward current	180° half sine wave 50Hz Double side cooled, T _c =85°C	175			1290	A
V _{RRM}	Repetitive peak reverse voltage	tp=10ms	175	1100		2000	V
I _{RRM}	Repetitive peak current	at V _{RRM}	175			40	mA
I _{FSM}	Surge forward current	10ms half sine wave	175			15	kA
I ² t	I ² t for fusing coordination	V _R =0.6V _{RRM}					1125
V _{FO}	Threshold voltage		175			1.05	V
r _F	Forward slope resistance						0.30
V _{FM}	Peak forward voltage	I _{FM} =1800A, F=15kHz	25			1.80	V
Q _{rr}	Recovery charge	I _{FM} =1000A, tp=4000μs, di/dt=-20A/μs, V _R =100V	175		1900		μC
R _{th(j-c)}	Thermal resistance Junction to case	At 180° sine double side cooled Clamping force 15.0kN				0.035	°C/W
R _{th(c-h)}	Thermal resistance case to heat sink					0.008	
F _m	Mounting force			10		20	kN
T _{vj}	Junction temperature			-40		175	°C
T _{stg}	Stored temperature			-40		175	°C
W _t	Weight				240		g
Outline	ZT33cT						

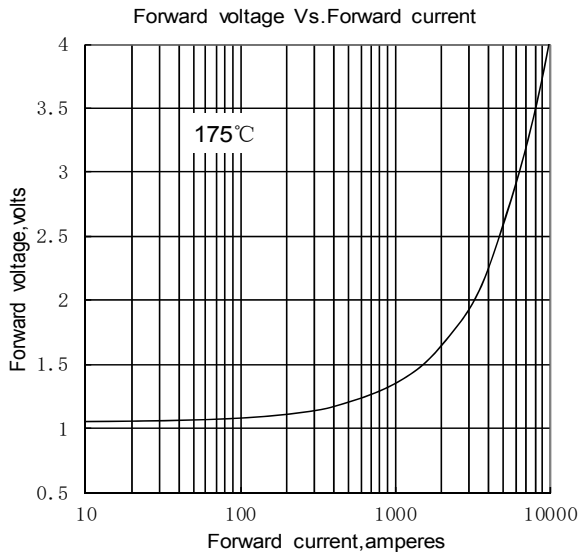

Fig.1

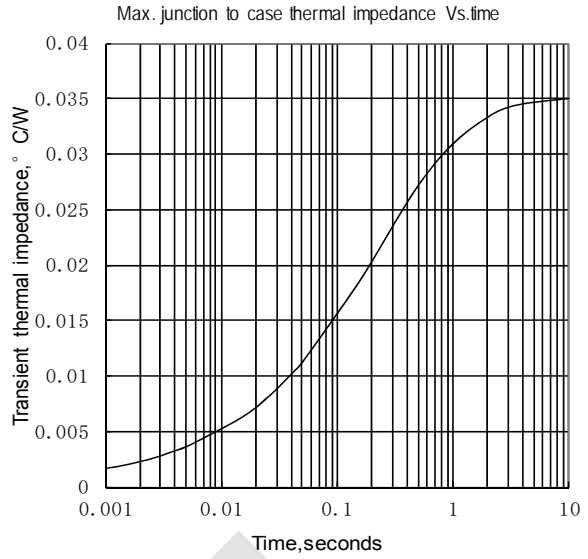

Fig.2

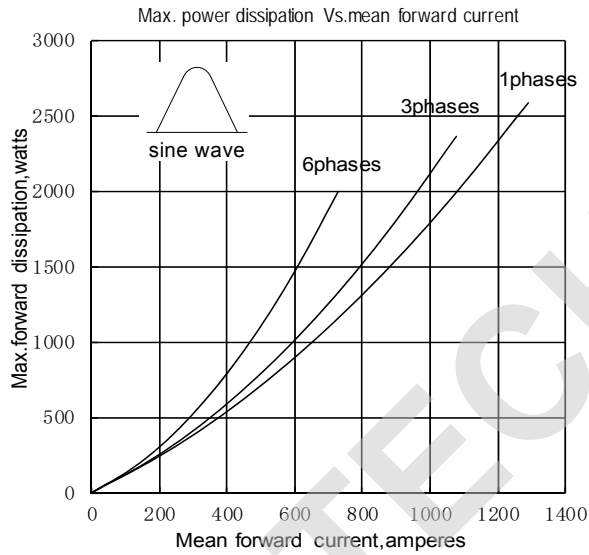

Fig.3

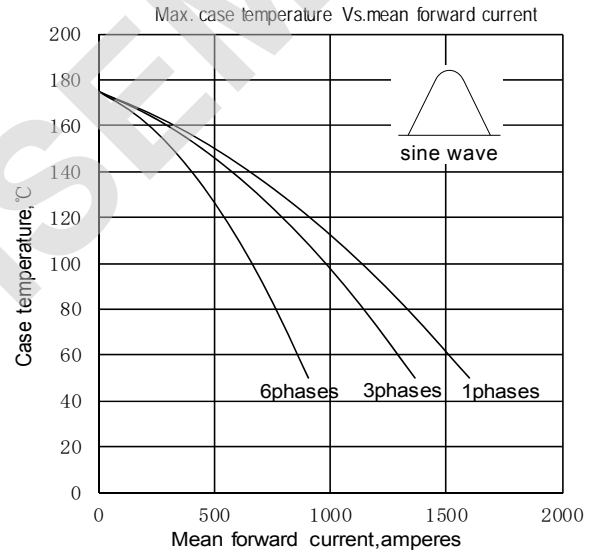

Fig.4

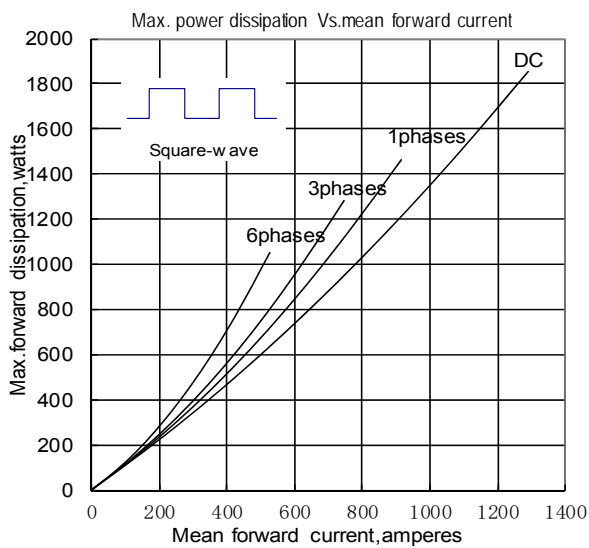

Fig.5

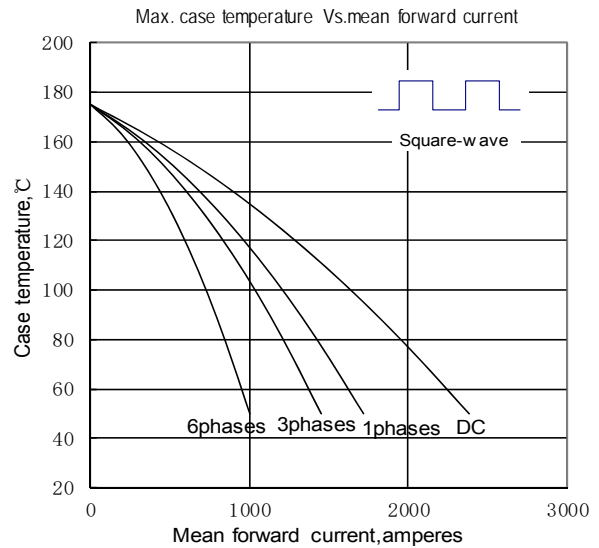

Fig.6

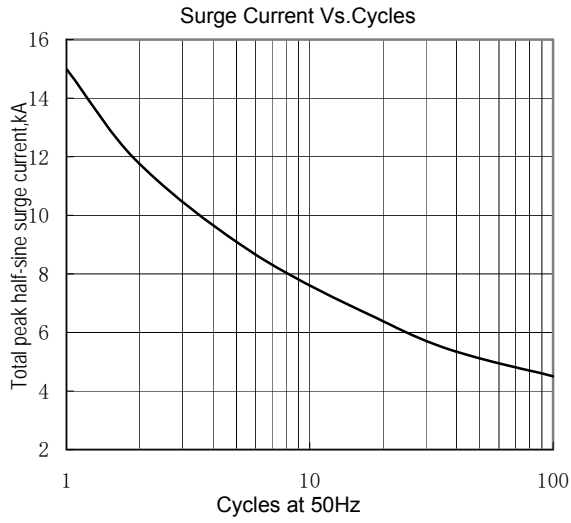

Fig.7

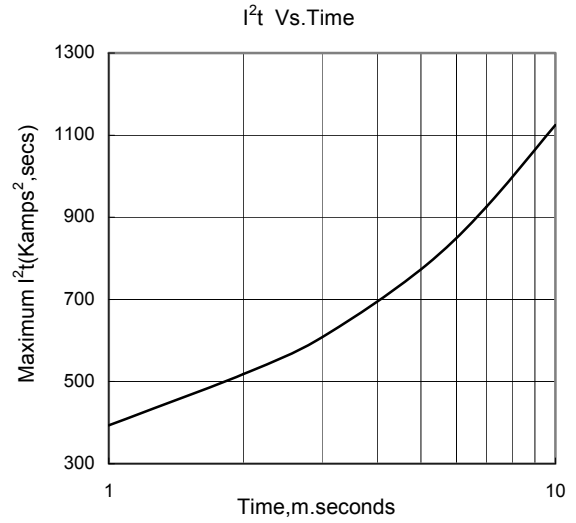
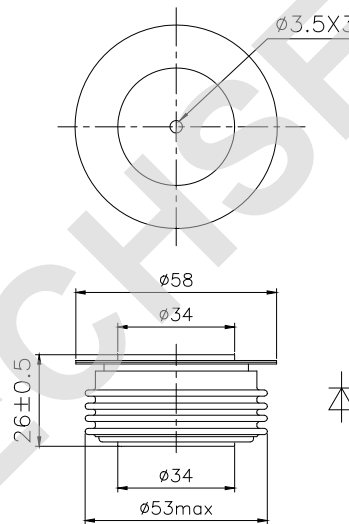

Fig.8

Outline:



TECHSEM reserves the right to change specifications without notice.