

**Features**

- Low forward voltage drop
- High reverse voltage
- Hermetic metal cases with ceramic insulators

Typical Applications

- All purpose high power rectifier diodes
- High power resistance welding equipment
- Non-controllable and half-controllable rectifiers
- Controlled rectifiers

Part No. Y89ZPD-ZT84cT

I_{F(AV)}	5060A
V_{RRM}	2200V 2500V 2800V 3000V

SYMBOL	CHARACTERISTIC	TEST CONDITIONS	T _J (°C)	VALUE			UNIT
				Min	Type	Max	
I _{F(AV)}	Mean forward current	180° half sine wave 50Hz Double side cooled, T _C =85°C	160			5060	A
V _{RRM}	Repetitive peak reverse voltage	tp=10ms	160	2100		3000	V
I _{RRM}	Repetitive peak current	At V _{RRM}	160			250	mA
I _{FSM}	Surge forward current	10ms half sine wave	160			63	kA
I ² t	I ² t for fusing coordination	V _R =0.6V _{RRM}					19845
V _{FO}	Threshold voltage		160			0.90	V
r _F	Forward slope resistance						0.098
V _{FM}	Peak forward voltage	I _{FM} =5000A, F=70kN	25			1.80	V
Q _{rr}	Recovery charge	I _{FM} =2000A, tp=4000μs, di/dt=-20A/μs, V _R =100V	160		7000		μC
R _{th(j-c)}	Thermal resistance Junction to case	At 180° sine double side cooled Clamping force 70kN				0.007	°C /W
R _{th(c-h)}	Thermal resistance case to heat sink					0.002	
F _m	Mounting force			63		84	kN
T _{vj}	Junction temperature			-40		160	°C
T _{stg}	Stored temperature			-40		160	°C
W _t	Weight				1390		g
Outline	ZT84cT						

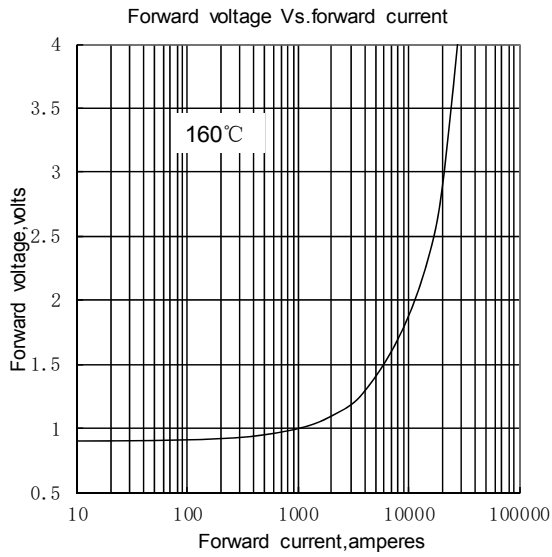

Fig.1

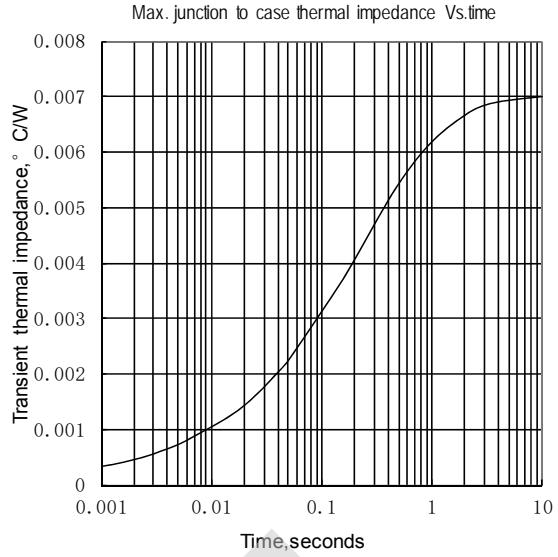

Fig.2

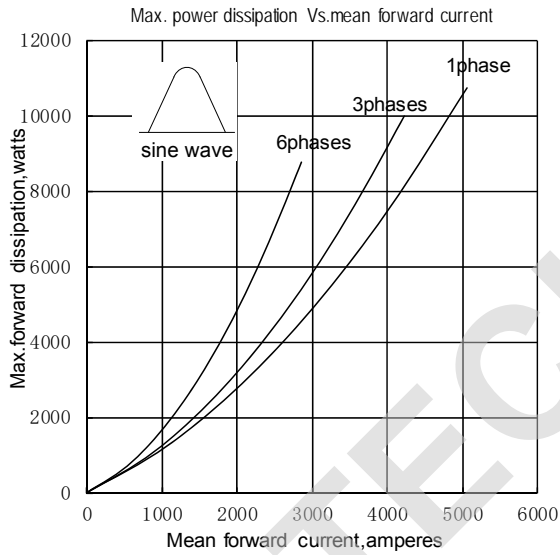

Fig.3

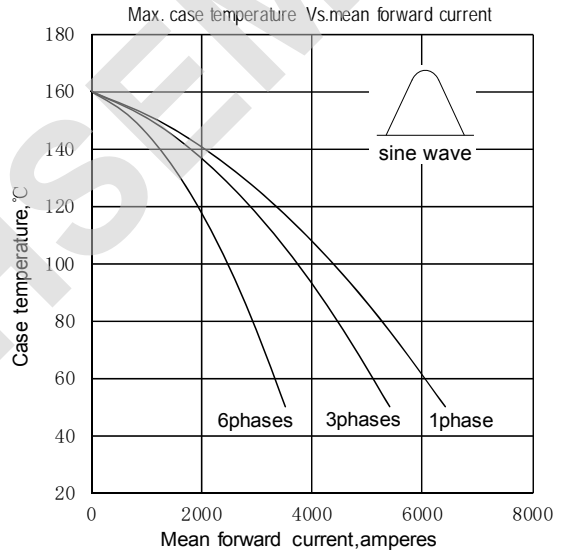

Fig.4

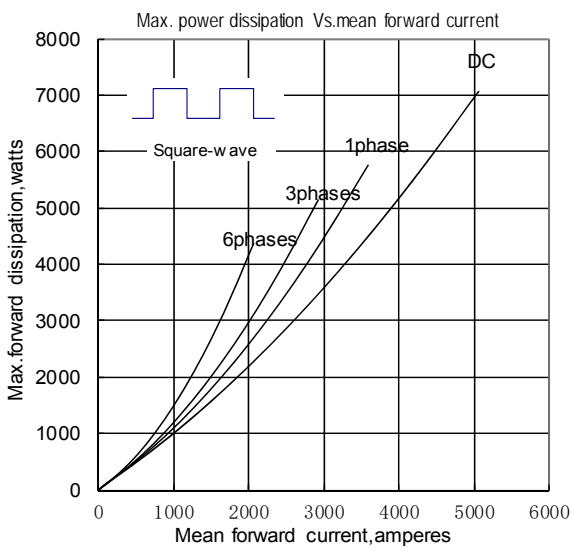

Fig.5

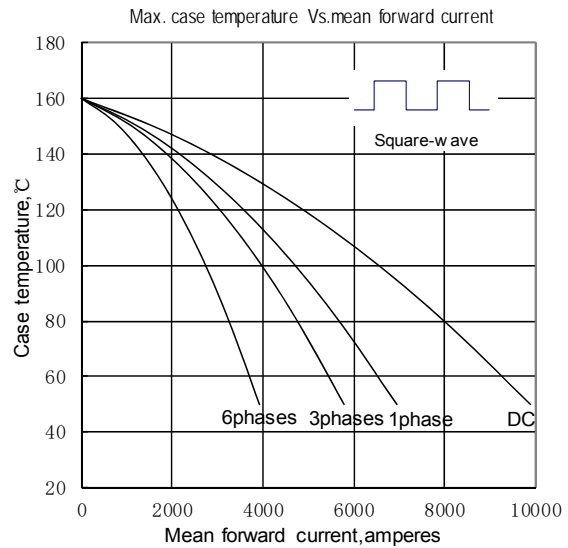

Fig.6

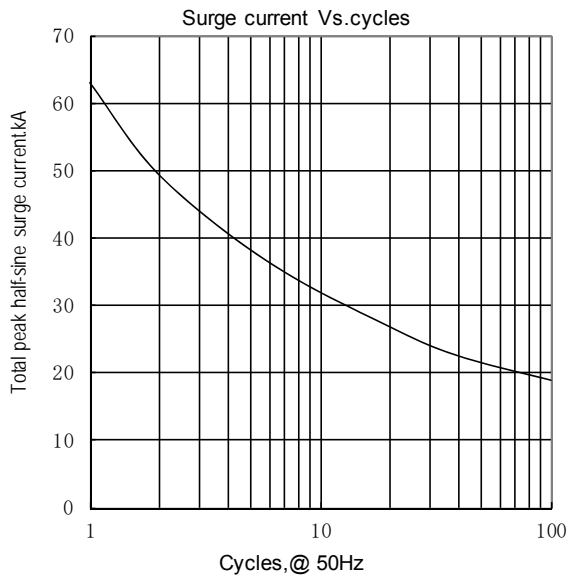

Fig.7

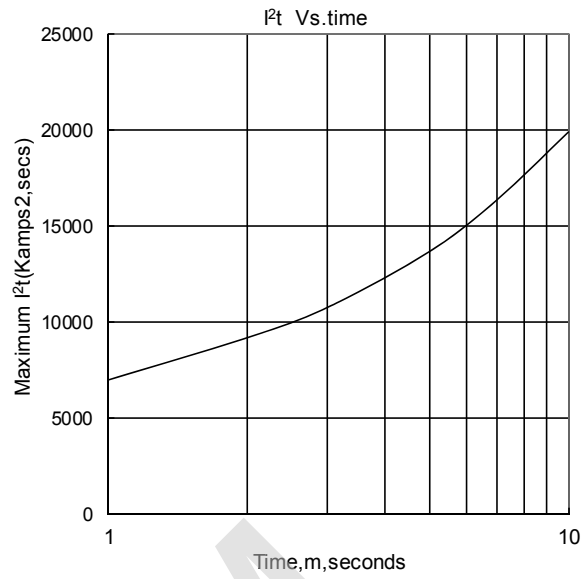
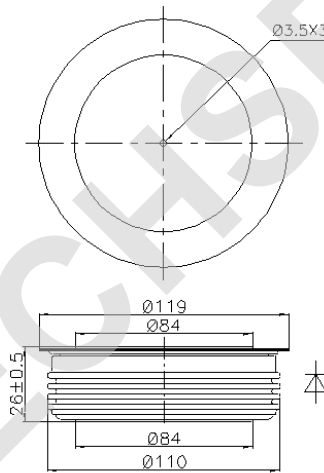

Fig.8

Outline:



TECHSEM reserves the right to change specifications without notice.