**Features**

- Low forward voltage drop
- High reverse voltage
- Hermetic metal cases with ceramic insulators

Typical Applications

- All purpose high power rectifier diodes
- High power resistance welding equipment
- Non-controllable and half-controllable rectifiers
- Controlled rectifiers

Part No. T38ZPR-ZT33c(d)T

I_{F(AV)}	500A
V_{RRM}	5600V 6000V 6500V

SYMBOL	CHARACTERISTIC	TEST CONDITIONS		T _J (°C)	VALUE			UNIT
					Min	Type	Max	
I _{F(AV)}	Mean forward current	180° half sine wave 50Hz Double side cooled,	T _C =100°C	150			500	A
V _{RRM}	Repetitive peak reverse voltage	tp=10ms		150	5600		6500	V
I _{RRM}	Repetitive peak current	at V _{RRM}		150			50	mA
I _{FSM}	Surge forward current	10ms half sine wave		150			9.5	kA
I ² t	I ² t for fusing coordination	V _R =0.6V _{RRM}					451	A ² s*10 ³
V _{FO}	Threshold voltage			150			0.89	V
r _F	Forward slope resistance						1.05	mΩ
V _{FM}	Peak forward voltage	I _{FM} =1000A, F=20kN		25			2.20	V
Q _{rr}	Recovery charge	I _{FM} =1000A, tp=4000μs, di/dt=-5A/μs, V _R =100V		150		2500		μC
R _{th(j-c)}	Thermal resistance Junction to case	At 180° sine double side cooled Clamping force 20.0kN					0.045	°C /W
R _{th(c-h)}	Thermal resistance case to heatsink						0.008	
F _m	Mounting force				10	15	20	kN
T _{vj}	Junction temperature				-40		150	°C
T _{stg}	Stored temperature				-40		160	°C
W _t	Weight					340		g
Outline	ZT33cT / ZT33dT							

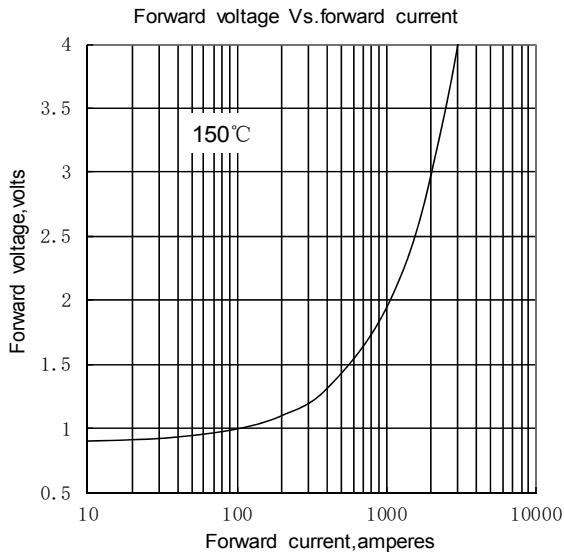

Fig.1

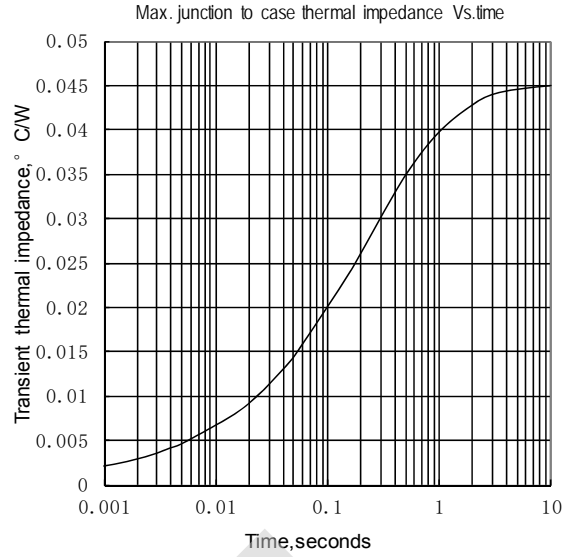

Fig.2

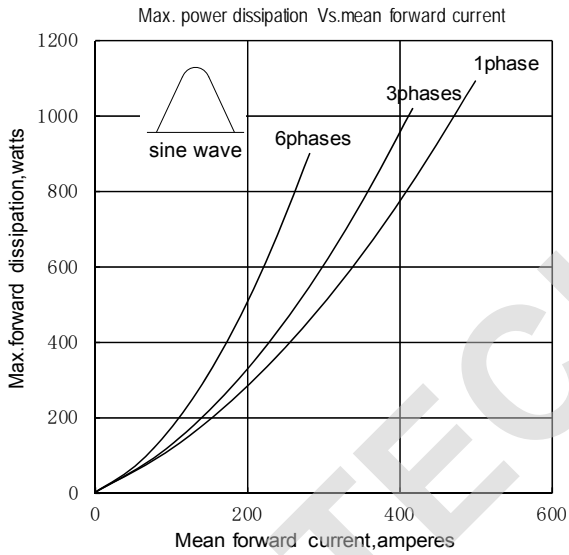

Fig.3

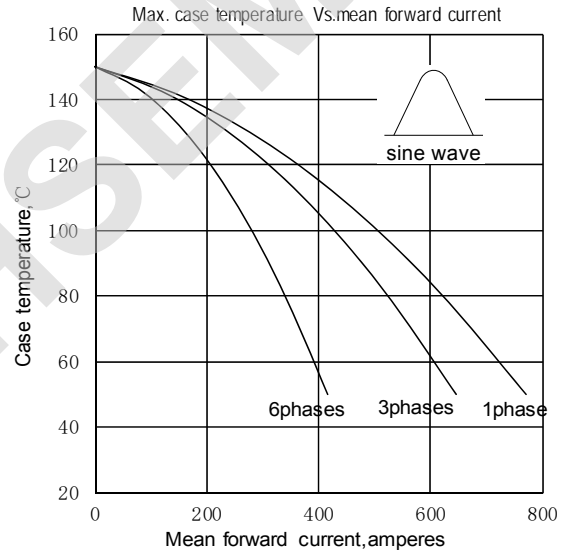

Fig.4

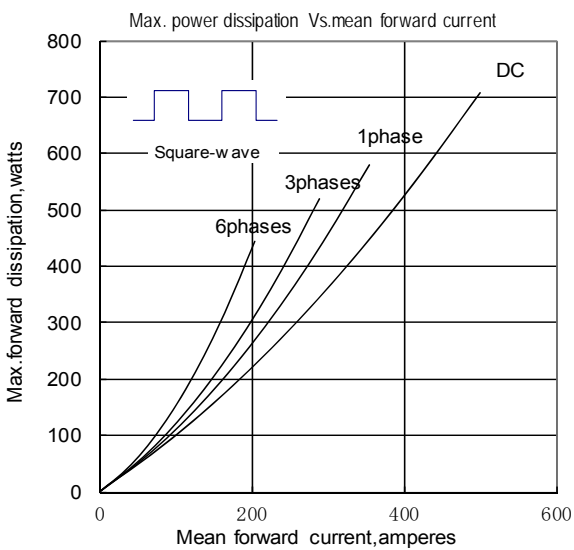

Fig.5

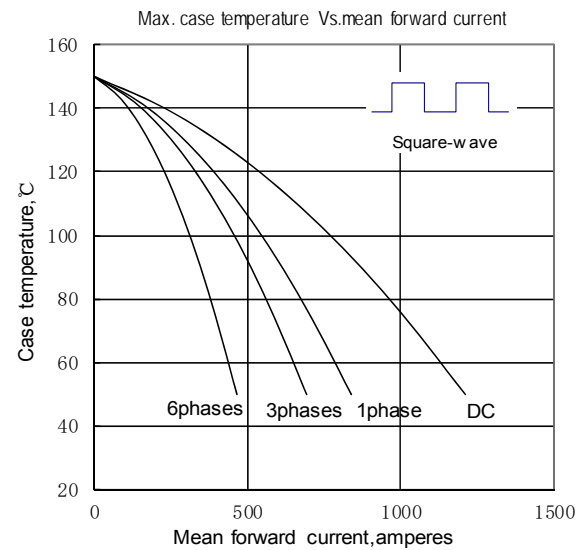

Fig.6

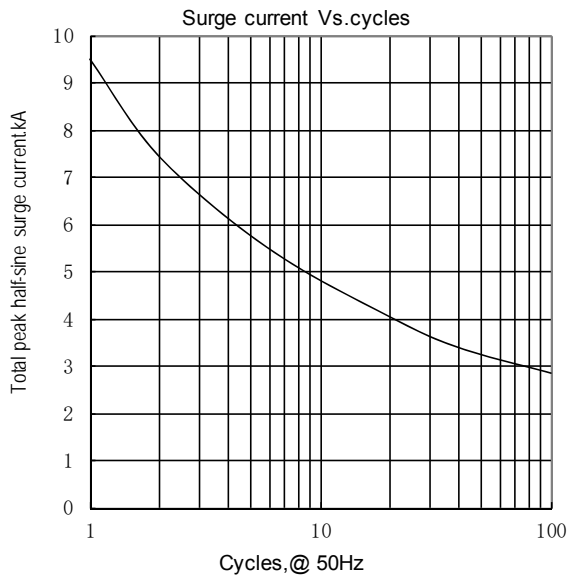

Fig.7

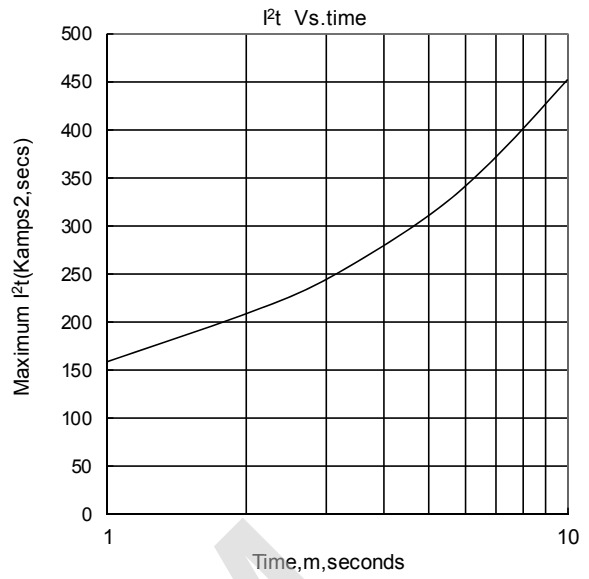
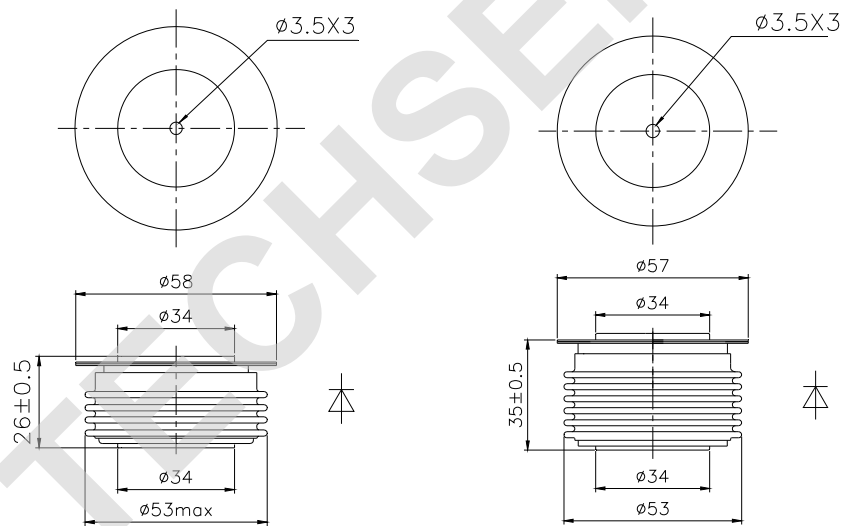

Fig.8

Outline:



TECHSEM reserves the right to change specifications without notice.