



Features:

- Isolated mounting base 3000V~
- Pressure contact technology with Increased power cycling capability
- Space and weight saving

Typical Applications:

- Various rectifiers
- DC supply for PWM inverter

| V _{RRM} | Type & Outline |
|------------------|------------------|
| 2000V | MDx300-20-413F3D |
| 2200V | MDx300-22-413F3D |
| 2500V | MDx300-25-413F3D |
| 2500V | MD300-25-413F3DG |

MDx stands for any type of **MDC, MDA, MDK**

| SYMBOL | CHARACTERISTIC | TEST CONDITIONS | T _j (°C) | VALUE | | | UNIT |
|----------------------|--|---|---------------------|-------|------|------|----------------------------------|
| | | | | Min | Type | Max | |
| I _{F(AV)} | Mean forward current | 180° half sine wave 50Hz Single side cooled, T _c =100°C | 150 | | | 300 | A |
| I _{F(RMS)} | RMS forward current | | | | | 471 | A |
| I _{RRM} | Repetitive peak current | at V _{RRM} | 150 | | | 20 | mA |
| I _{FSM} | Surge forward current | V _R =60%V _{RRM} , t=10ms half sine. | 150 | | | 9 | kA |
| I ² t | I ² t for fusing coordination | | | | | 500 | 10 ³ A ² s |
| V _{FO} | Threshold voltage | | 150 | | | 0.80 | V |
| r _F | Forward slope resistance | | | | | 0.50 | mΩ |
| V _{FM} | Peak forward voltage | I _{FM} =900A | 25 | | | 1.45 | V |
| R _{th(j-c)} | Thermal resistance Junction to case | Single side cooled per chip | | | | 0.12 | °C/W |
| R _{th(c-h)} | Thermal resistance case to heatsink | Single side cooled per chip | | | | 0.04 | °C/W |
| V _{iso} | Isolation voltage | 50Hz, R.M.S, t=1min, I _{iso} :1mA(MAX) | | 3000 | | | V |
| F _m | Terminal connection torque(M8) | | | 10 | | 12 | N·m |
| | Mounting torque(M6) | | | 4.5 | | 6 | N·m |
| T _{vj} | Junction temperature | | | -40 | | 150 | °C |
| T _{stg} | Stored temperature | | | -40 | | 125 | °C |
| W _t | Weight | | | | 770 | | g |
| Outline | 413F3D | | | | | | |

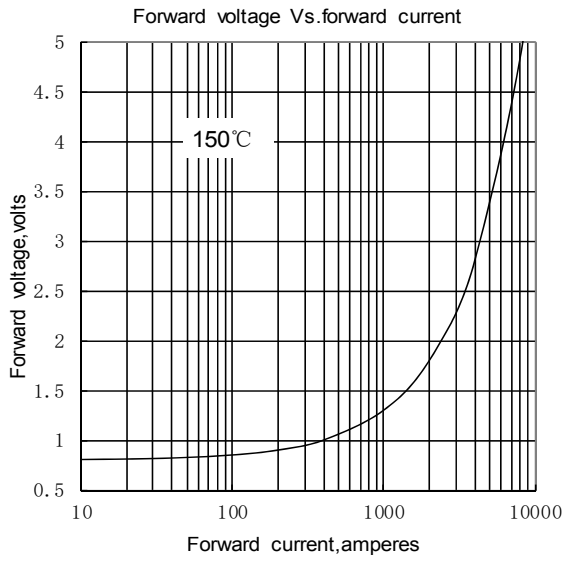

Fig.1

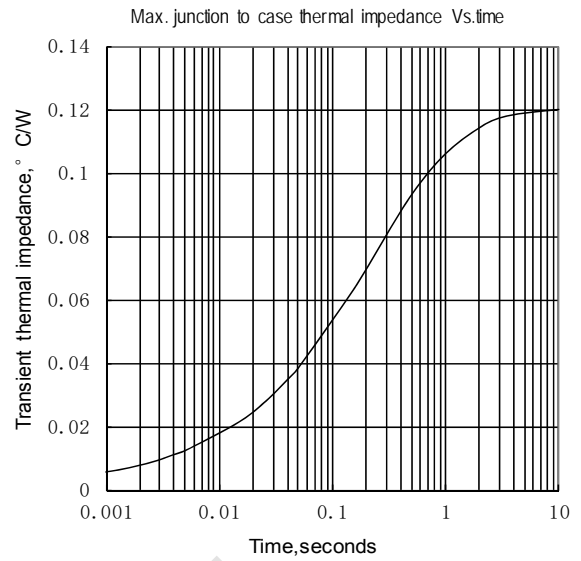

Fig.2

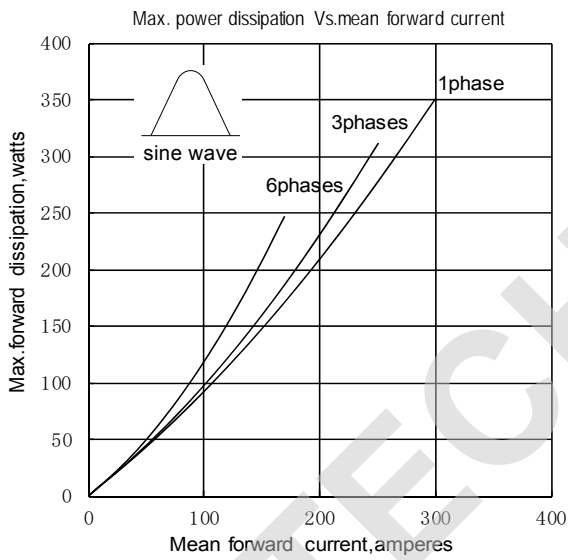

Fig.3

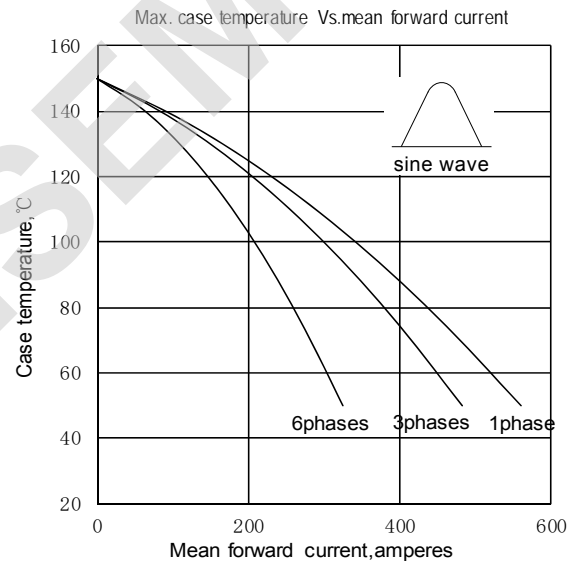

Fig.4

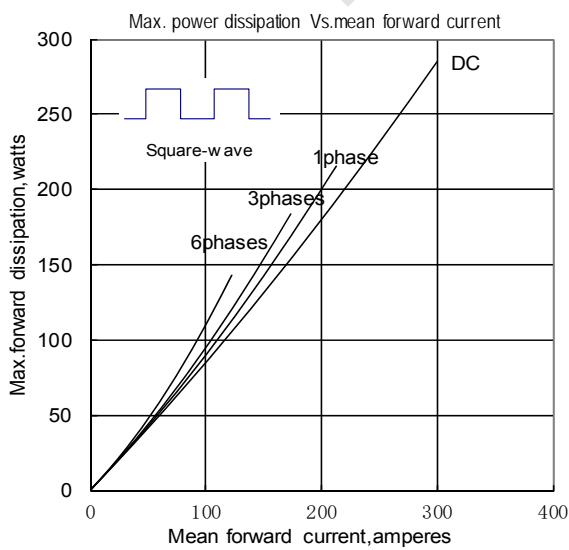

Fig.5

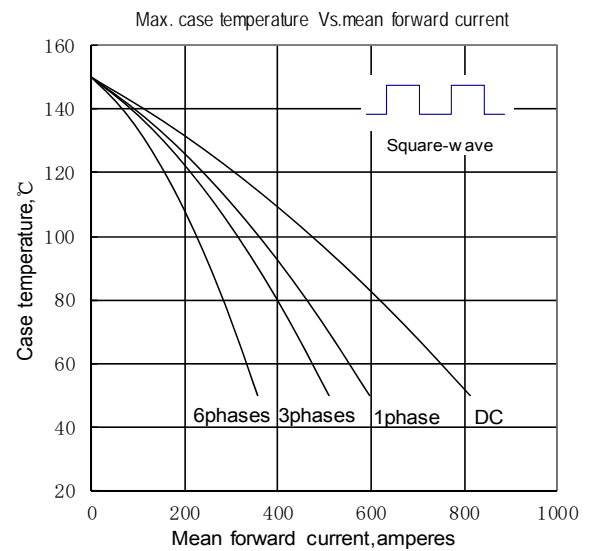

Fig.6

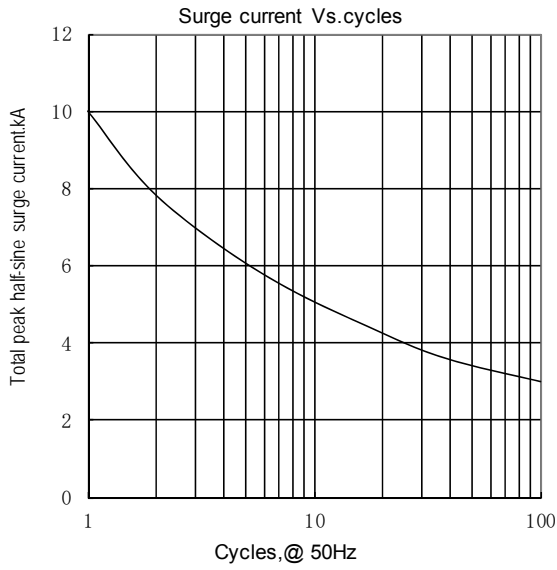

Fig.7

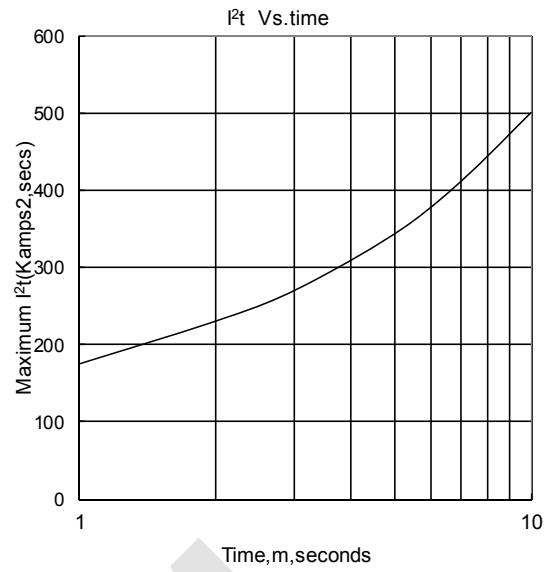
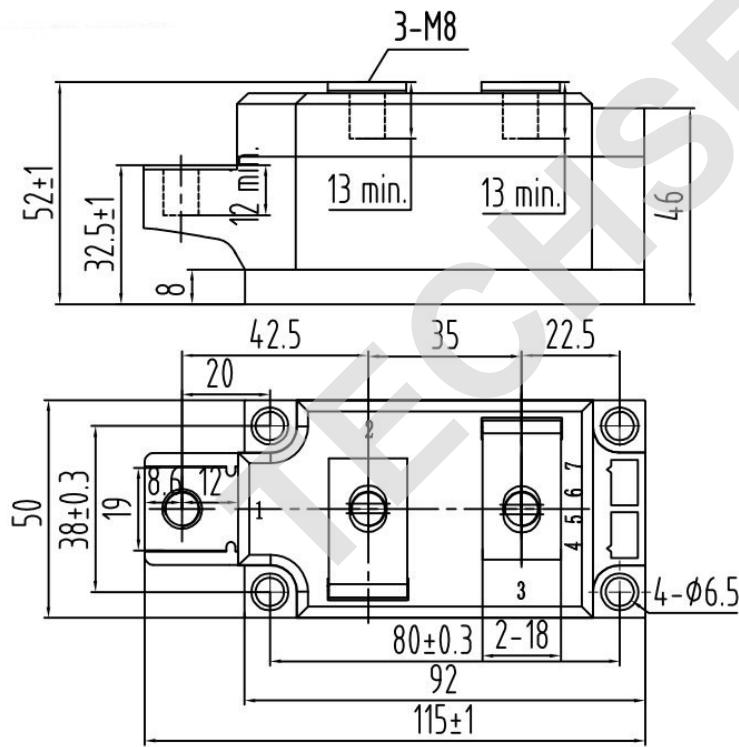

Fig.8

Outline:



Unmarked dimensional tolerance: ±0.5mm

