

**Features**

- Interdigitated amplifying gates
- Fast turn-on and high di/dt
- Low switching losses

**Typical Applications**

- Pulsed power
- Ignitron Replacement

**Part No. H150KMR-KT140dT**

**I<sub>PK</sub> 300kA**  
**V<sub>DRM</sub>, V<sub>RRM</sub> 6000V 6500V**

SYMBOL	CHARACTERISTIC	TEST CONDITIONS	T <sub>j</sub> (°C)	VALUE			UNIT
				Min	Type	Max	
I <sub>pk</sub>	Pulse peak on-state current	Single pulse sine wave tp: 500µs	110			300	kA
I <sub>T(AV)</sub>	Mean on-state current	180° half sine wave 50Hz Double side cooled, T <sub>C</sub> =70°C	110			6000	A
V <sub>DRM</sub> V <sub>RRM</sub>	Repetitive peak off-state voltage Repetitive peak reverse voltage	tp=10ms	110	6000		6500	V
I <sub>DRM</sub> I <sub>RRM</sub>	Repetitive peak current	at V <sub>DRM</sub> at V <sub>RRM</sub>	110			500	mA
I <sub>TSM</sub>	Surge on-state current	10ms half sine wave	110			75	kA
I <sup>2</sup> t	I <sup>2</sup> t for fusing coordination	V <sub>R</sub> =0.6V <sub>RRM</sub>				28125	A <sup>2</sup> s*10 <sup>3</sup>
V <sub>TM</sub>	Peak on-state voltage	I <sub>TM</sub> =5000A, F=120kN, tp=10ms	25			2.4	V
dv/dt	Critical rate of rise of off-state voltage	V <sub>DM</sub> =0.67V <sub>DRM</sub>	110			2000	V/µs
di/dt	Critical rate of rise of on-state current	Gate pulse t <sub>r</sub> ≤ 0.5µs I <sub>GM</sub> =1.5A	110			3000	A/µs
Q <sub>rr</sub>	Recovery charge	I <sub>TM</sub> =2000A, tp=4000µs, di/dt=-20A/µs, V <sub>R</sub> =100V	110		24000		µC
I <sub>GT</sub>	Gate trigger current	V <sub>A</sub> =12V, I <sub>A</sub> =1A	25	40		300	mA
V <sub>GT</sub>	Gate trigger voltage			0.8		3.5	V
I <sub>H</sub>	Holding current			20		1000	mA
I <sub>L</sub>	Latching current					1000	mA
V <sub>GD</sub>	Non-trigger gate voltage	V <sub>DM</sub> =67%V <sub>DRM</sub>	110	0.25			V
R <sub>th(j-c)</sub>	Thermal resistance Junction to case	At 180° sine-double side cooled Clamping force 120 kN				0.0028	°C /W
R <sub>th(c-h)</sub>	Thermal resistance case to heat sink					0.0008	°C /W
F <sub>m</sub>	Mounting force			165		190	kN
T <sub>vj</sub>	Junction temperature			-40		110	°C
T <sub>stg</sub>	Stored temperature			-40		140	°C
W <sub>t</sub>	Weight				4000		g
Outline	KT140dT						

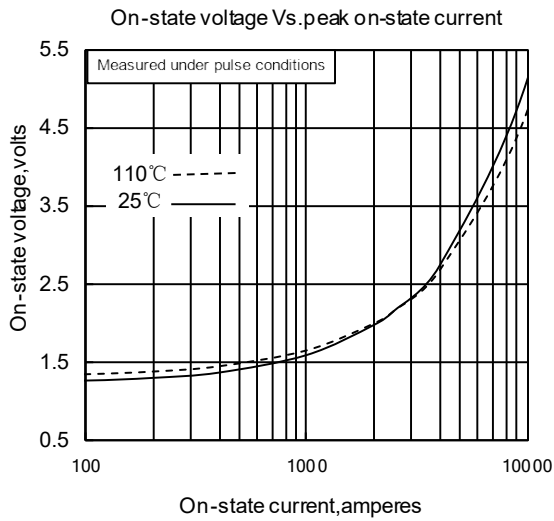

Fig. 1

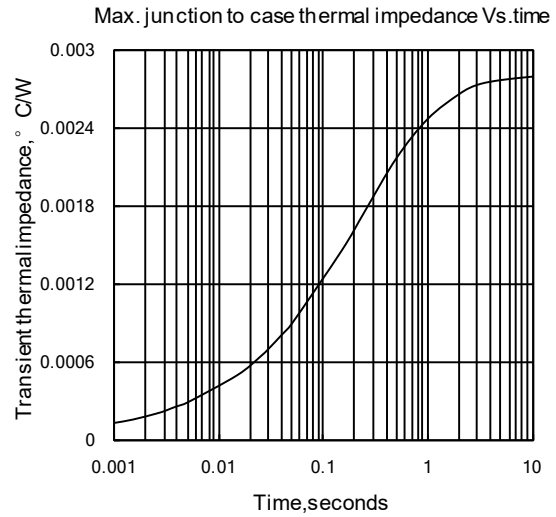

Fig. 2

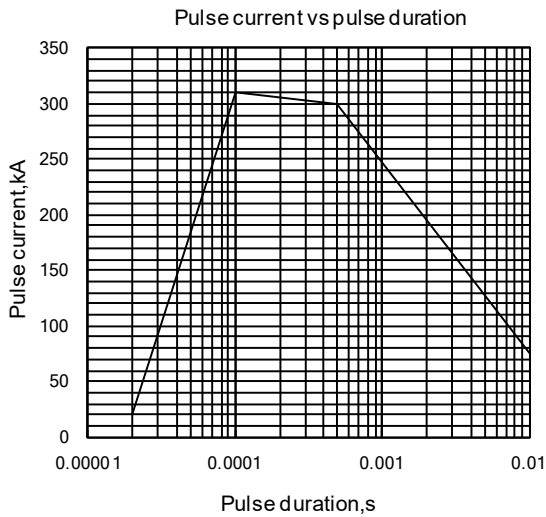

Fig. 3

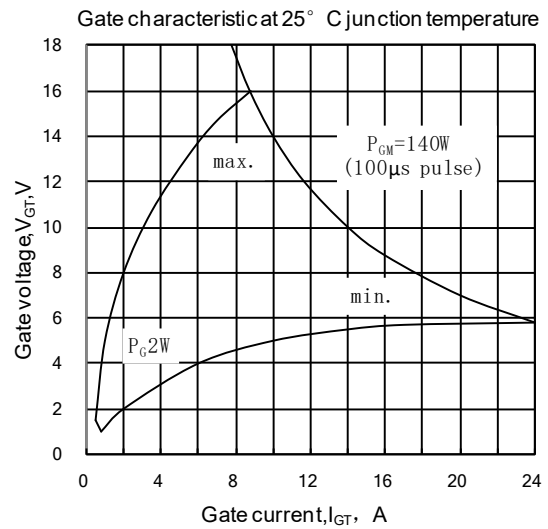

Fig. 4

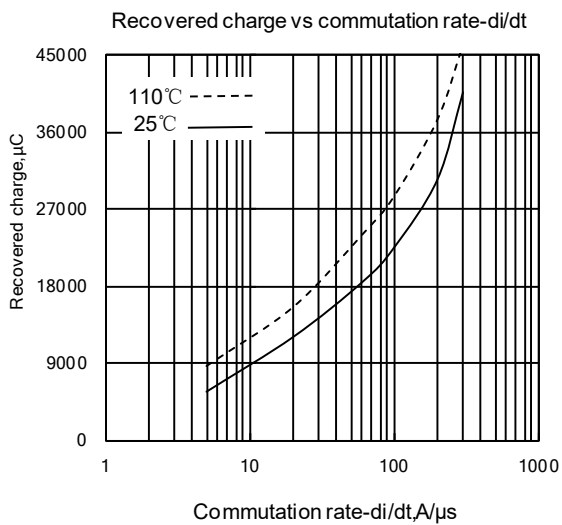

Fig. 5

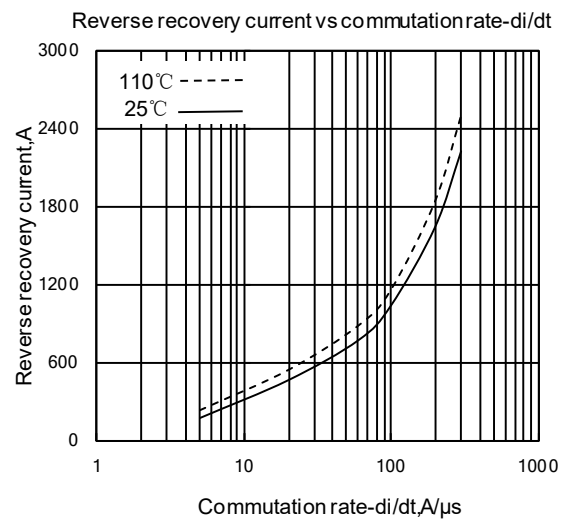
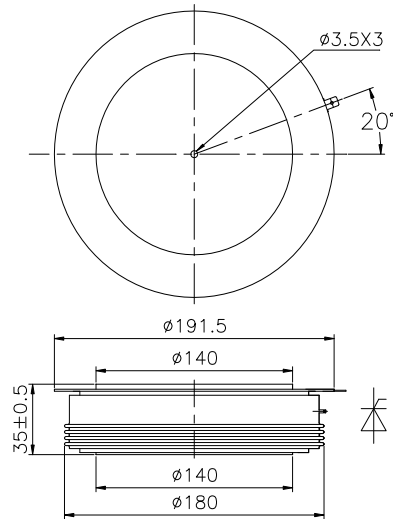

Fig. 6

Outline:



TECHSEM reserves the right to change specifications without notice.