

Features

- n Center amplifying gate
- n Metal case with ceramic insulator
- n Low on-state and switching losses

Typical Applications

- n AC controllers
- n DC and AC motor control
- n Controlled rectifiers

Part No. Y60KPH-KT54cT

I_{T(AV)}	1800A	
V_{DRM}, V_{RRM}	2000V	2200V
	2500V	2800V
	3000V	

SYMBOL	CHARACTERISTIC	TEST CONDITIONS	T _j (°C)	VALUE			UNIT
				Min	Type	Max	
I _{T(AV)}	Mean on-state current	180° half sine wave 50Hz Double side cooled, T _C =70°C	125			1800	A
V _{DRM} V _{RRM}	Repetitive peak off-state voltage Repetitive peak reverse voltage	tp=10ms	125	1900		3000	V
I _{DRM} I _{RRM}	Repetitive peak current	at V _{DRM} at V _{RRM}	125			120	mA
I _{TSM}	Surge on-state current	10ms half sine wave V _R =0.6V _{RRM}	125			23.6	kA
I ² t	I ² t for fusing coordination					2785	A ² s*10 ³
V _{TO}	Threshold voltage		125			0.98	V
r _T	On-state slope resistance					0.21	mΩ
V _{TM}	Peak on-state voltage	I _{TM} =3000A, F=28kN	25			2.30	V
dv/dt	Critical rate of rise of off-state voltage	V _{DM} =0.67V _{DRM}	125			1000	V/μs
di/dt	Critical rate of rise of on-state current	V _{DM} = 67%V _{DRM} to2000A, Gate pulse t _r ≤0.5μs I _{GM} =1.5A Repetitive	125			200	A/μs
Q _{rr}	Recovery charge	I _{TM} =1000A, tp=4000μs, di/dt=-20A/μs, V _R =100V	125		1600		μC
I _{GT}	Gate trigger current	V _A =12V, I _A =1A	25	40		300	mA
V _{GT}	Gate trigger voltage			0.8		3.0	V
I _H	Holding current			20		300	mA
I _L	Latching current					1000	mA
V _{GD}	Non-trigger gate voltage	V _{DM} =67%V _{DRM}	125			0.3	V
R _{th(j-c)}	Thermal resistance Junction to case	At 180° sine double side cooled Clamping force 28.0kN				0.016	°C/W
R _{th(c-h)}	Thermal resistance case to heatsink					0.004	
F _m	Mounting force			21		30	kN
T _{vj}	Junction temperature			-40		125	°C
T _{stg}	Stored temperature			-40		140	°C
W _t	Weight				640		g
Outline	KT54cT						

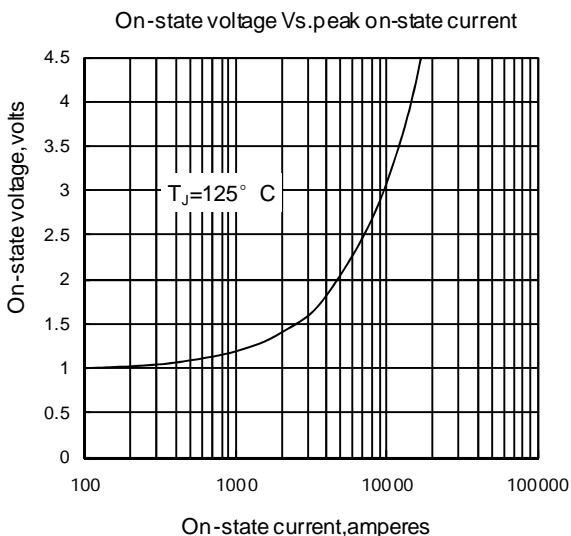

Fig 1

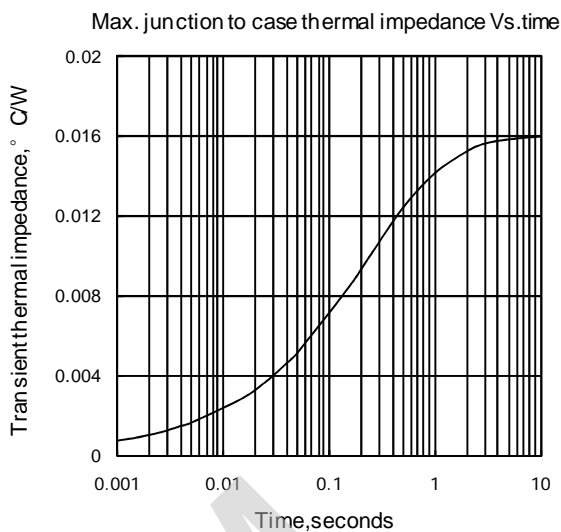

Fig 2

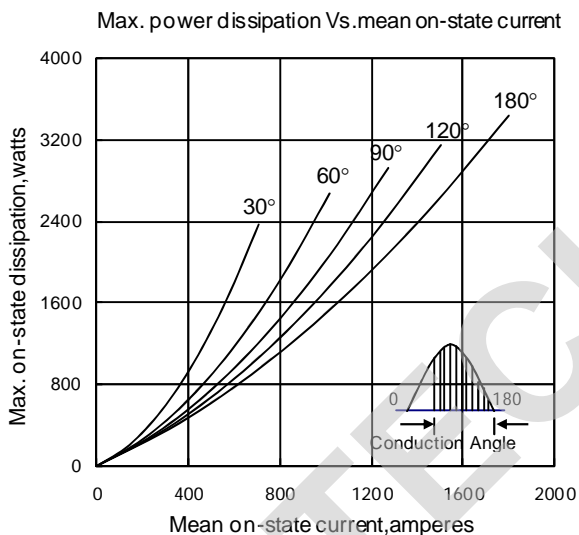

Fig 3

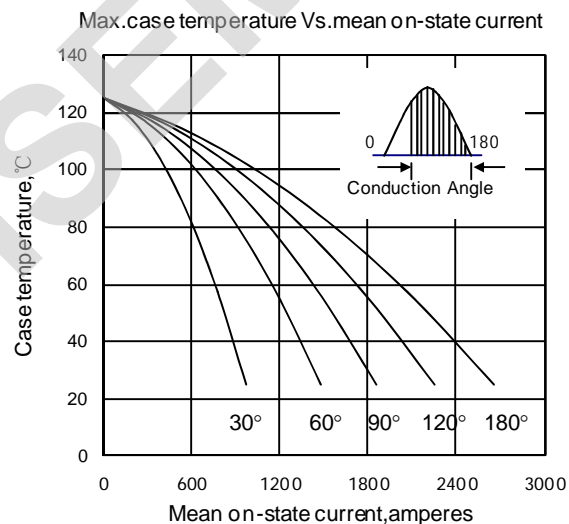

Fig 4

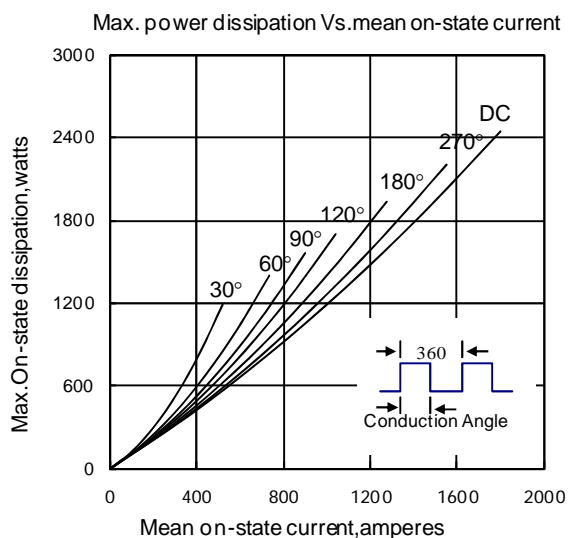

Fig 5

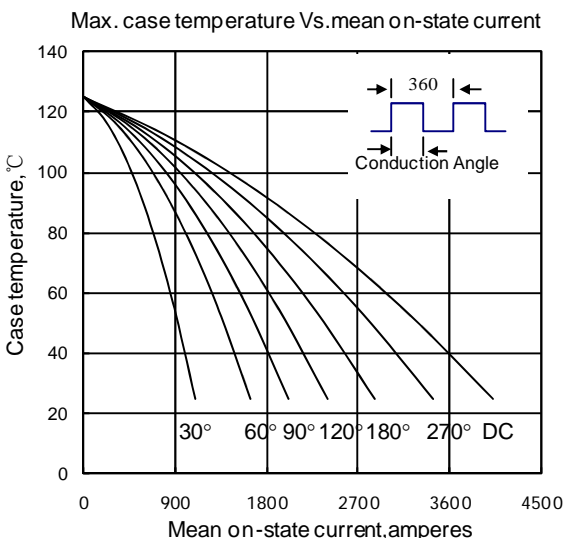

Fig 6

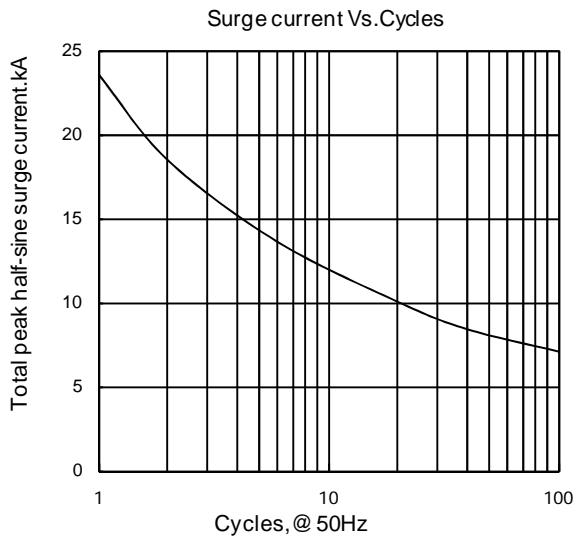

Fig 7

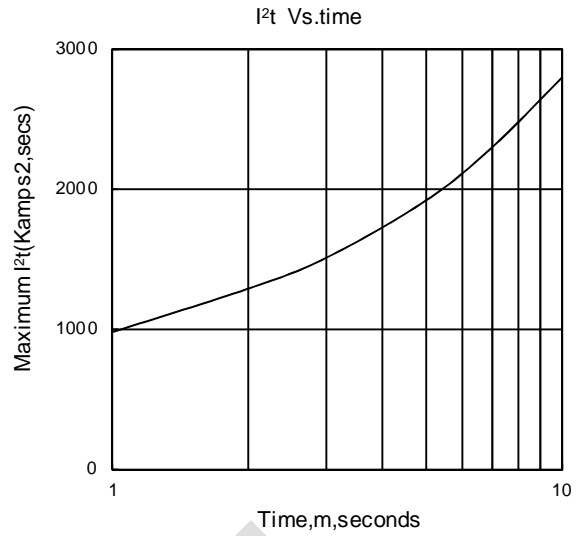

Fig 8

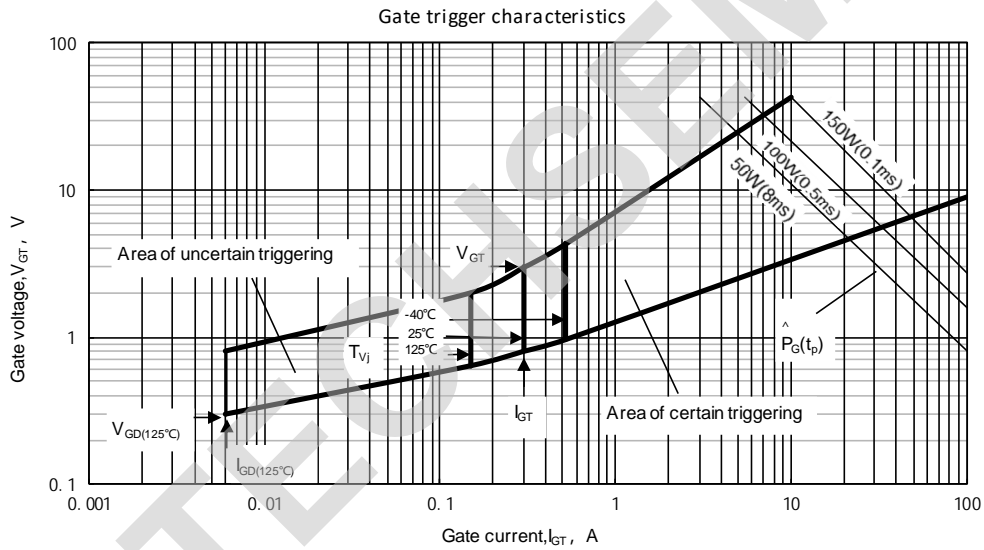
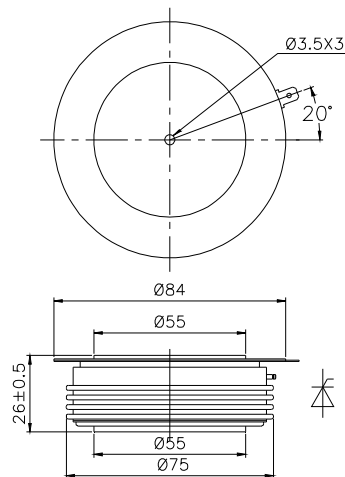

Fig.9

Outline:



TECHSEM reserves the right to change specifications without notice.