

**Features**

- n Low forward voltage drop
- n High reverse voltage
- n Hermetic metal cases with ceramic insulators

Typical Applications

- n All purpose high power rectifier diodes
- n High power resistance welding equipment
- n Non-controllable and half-controllable rectifiers
- n Controlled rectifiers

Part No. T65ZPR-ZT60c(d)T

I_{F(AV)}	970A
V_{RRM}	5600V 6000V 6500V

SYMBOL	CHARACTERISTIC	TEST CONDITIONS	T _j (°C)	VALUE			UNIT
				Min	Type	Max	
I _{F(AV)}	Mean forward current	180° half sine wave 50Hz Double side cooled, T _C =100°C	150			1510	A
V _{RRM}	Repetitive peak reverse voltage	tp=10ms	150	5600		6500	V
I _{RRM}	Repetitive peak current	At V _{RRM}	150			150	mA
I _{FSM}	Surge forward current	10ms half sine wave	150			26	kA
I ² t	I ² t for fusing coordination	V _R =0.6V _{RRM}				3380	A ² s*10 ³
V _{FO}	Threshold voltage		150			0.92	V
r _F	Forward slope resistance					0.39	mΩ
V _{FM}	Peak forward voltage	I _{FM} =3000A, F=34kN	25			1.85	V
Q _{rr}	Recovery charge	I _{FM} =1000A, tp=4000μs, di/dt=-20A/μs, V _R =100V	150		5000		μC
R _{th(j-c)}	Thermal resistance Junction to case	At 180° sine double side cooled Clamping force 34kN				0.014	°C/W
R _{th(c-h)}	Thermal resistance case to heatsink					0.0035	
F _m	Mounting force			27		34	kN
T _{vj}	Junction temperature			-40		150	°C
T _{stg}	Stored temperature			-40		160	°C
W _t	Weight				820/ 1100		g
Outline	ZT60cT / ZT60dT						

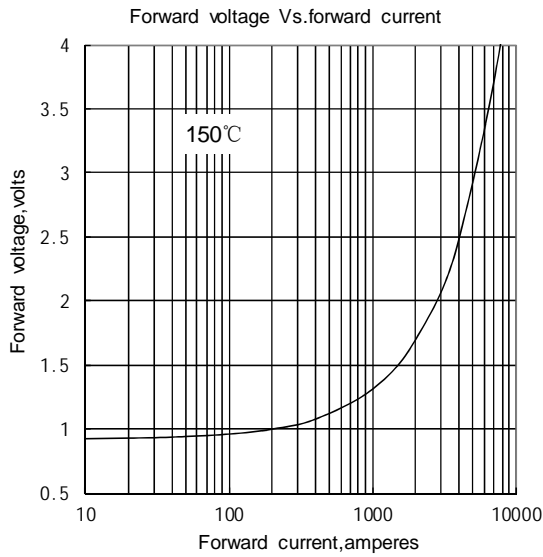

Fig.1

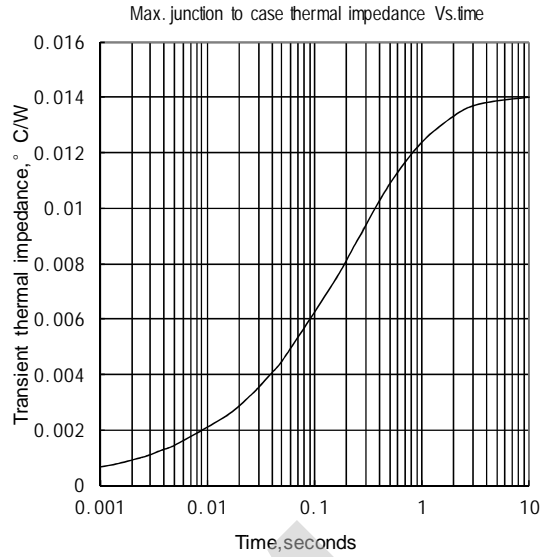

Fig.2

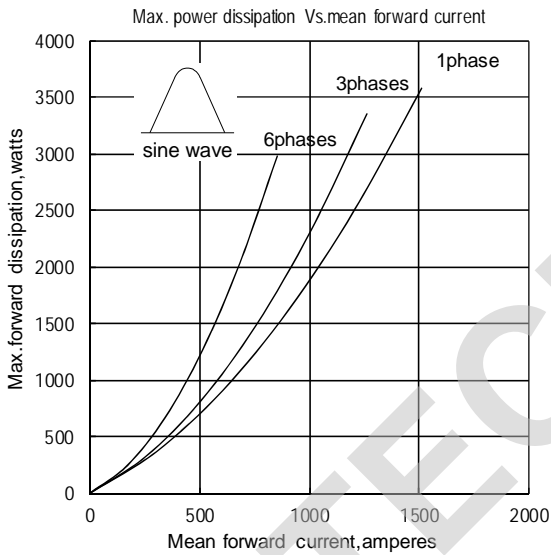

Fig.3

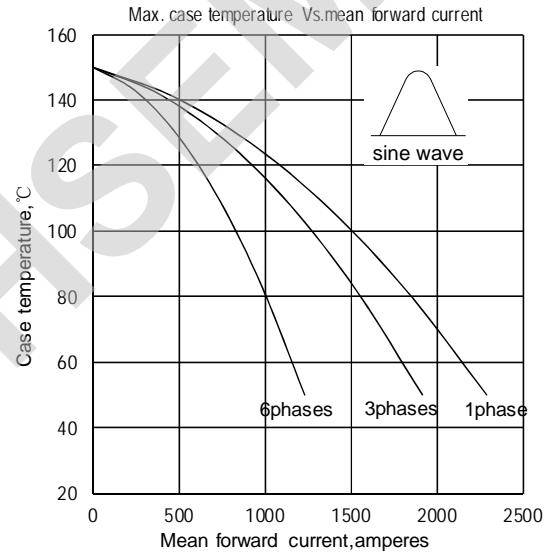

Fig.4

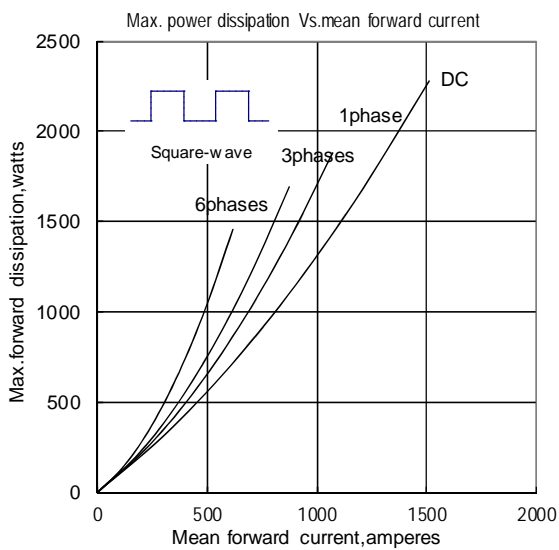

Fig.5

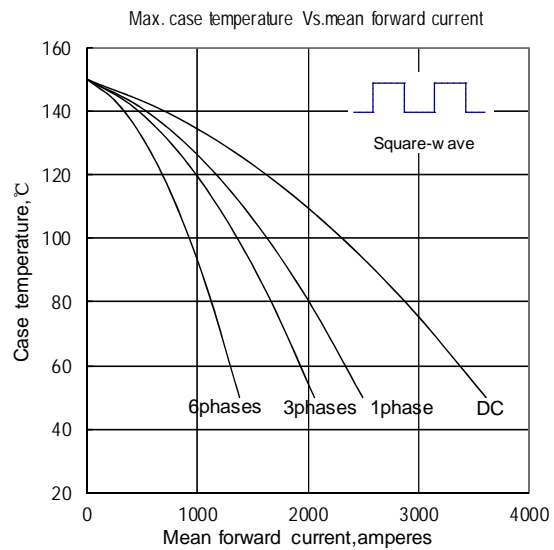

Fig.6

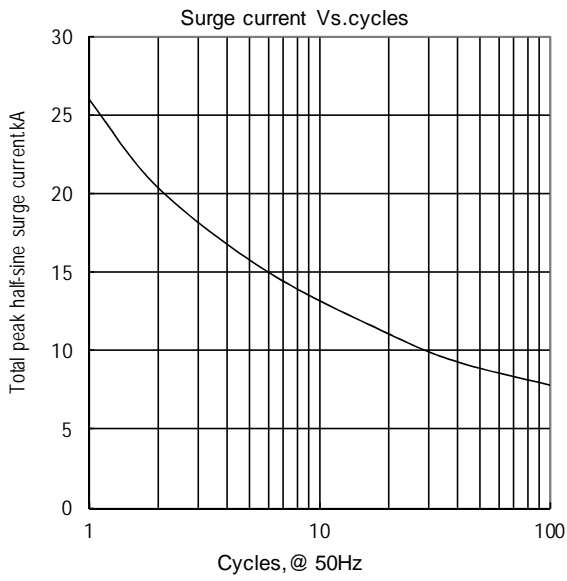

Fig.7

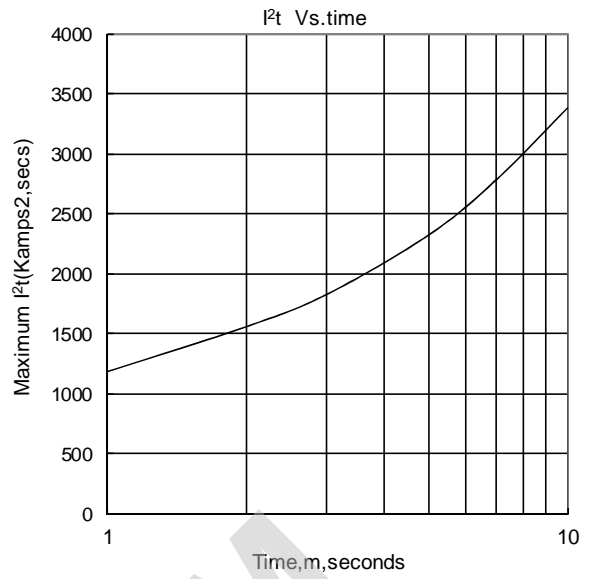
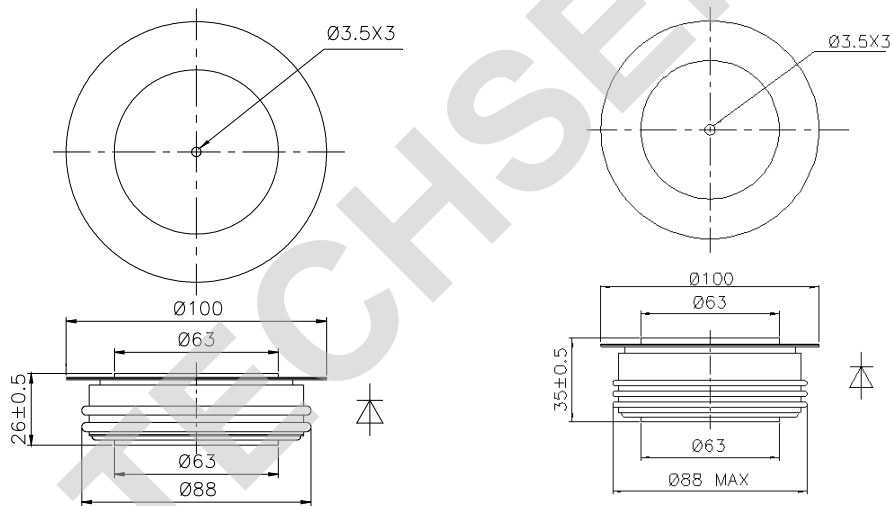

Fig.8

Outline:



TECHSEM reserves the right to change specifications without notice.