



Features:

- n Isolated mounting base 3000V~
- n Pressure contact technology with Increased power cycling capability
- n Space and weight saving

Typical Applications:

- n AC/DC Motor drives
- n Various rectifiers
- n DC supply for PWM inverter

V _{RRM} , V _{DRM}	Type & Outline	
600V	MTx1500-06-436F3	MFx1500-06-436F3
800V	MTx1500-08-436F3	MFx1500-08-436F3
1000V	MTx1500-10-436F3	MFx1500-10-436F3
1200V	MTx1500-12-436F3	MFx1500-12-436F3
1400V	MTx1500-14-436F3	MFx1500-14-436F3
1600V	MTx1500-16-436F3	MFx1500-16-436F3
1800V	MTx1500-18-436F3	MFx1500-18-436F3
1800V	MT1500-18-436F3G	

MTx stands for any type of **MTC, MTA, MTK**
 MFx stands for any type of **MFC, MFA, MFK**

SYMBOL	CHARACTERISTIC	TEST CONDITIONS	T _j (°C)	VALUE			UNIT
				Min	Type	Max	
I _{T(AV)}	Mean on-state current	180° half sine wave 50Hz Single side cooled, T _C =70°C	125			1500	A
I _{DRM} I _{RDM}	Repetitive peak current	at V _{DRM} at V _{RDM}	125			130	mA
I _{TSM}	Surge on-state current	V _R =60%V _{RRM} , t=10ms half sine,	125			30	kA
I ² t	I ² t for fusing coordination		125			4500	10 ³ A ² s
V _{TO}	Threshold voltage		125			0.80	V
r _T	On-state slope resistance					0.14	mΩ
V _{TM}	Peak on-state voltage	I _{TM} =3000A	25			1.60	V
dv/dt	Critical rate of rise of off-state voltage	V _{DM} =67%V _{DRM}	125			1000	V/μs
di/dt	Critical rate of rise of on-state current	Gate source 1.5A t _r ≤0.5μs Repetitive	125			200	A/μs
I _{GT}	Gate trigger current	V _A =12V, I _A =1A	25	40		200	mA
V _{GT}	Gate trigger voltage			0.8		3.0	V
I _H	Holding current			20		200	mA
V _{GD}	Non-trigger gate voltage	V _{DM} =67%V _{DRM}	125			0.20	V
R _{th(j-c)}	Thermal resistance Junction to case	Single side cooled per chip				0.025	°C/W
R _{th(c-h)}	Thermal resistance case to heatsink	Single side cooled per chip				0.018	°C/W
V _{iso}	Isolation voltage	50Hz, R.M.S, t=1min, I _{iso} :1mA(MAX)		3000			V
F _m	Terminal connection torque(M16)				20		N·m
	Mounting torque(M12)				14		N·m
T _{vj}	Junction temperature			-40		125	°C
T _{stg}	Stored temperature			-40		125	°C
W _t	Weight				6800		g
Outline	436F3						

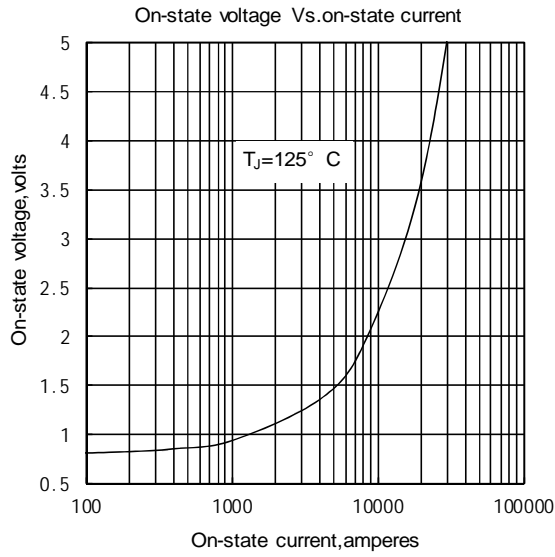

Fig.1

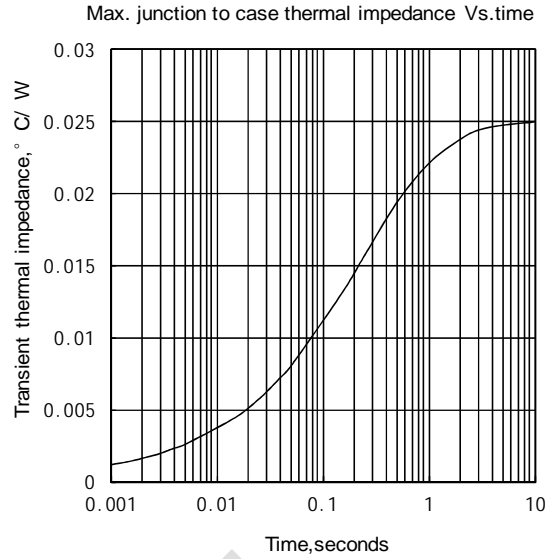

Fig.2

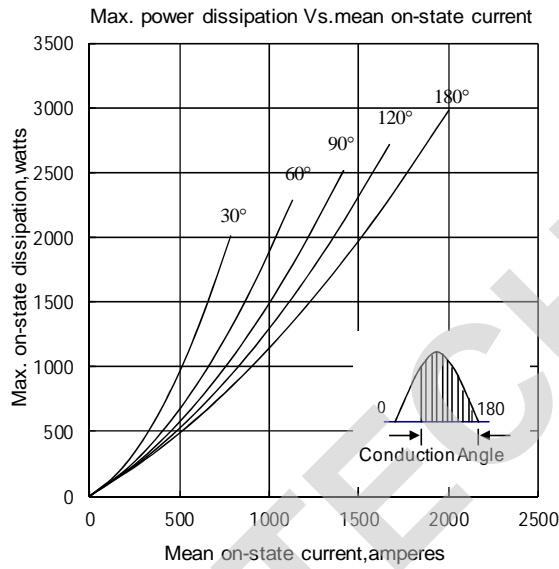

Fig.3

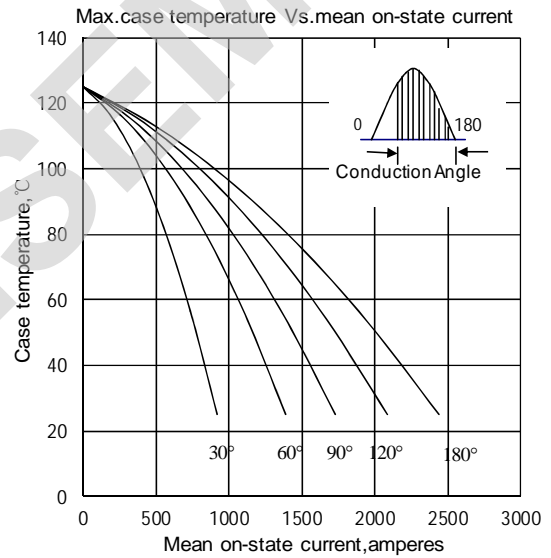

Fig.4

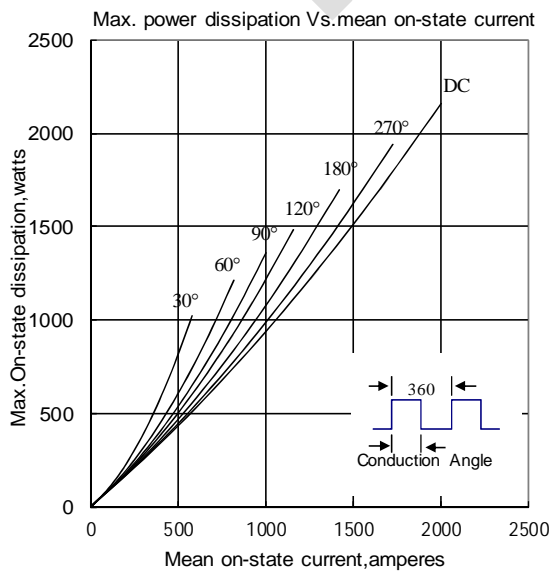

Fig.5

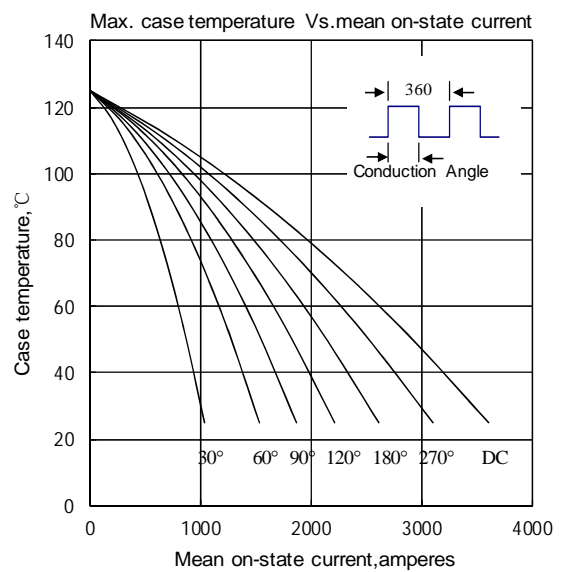

Fig.6

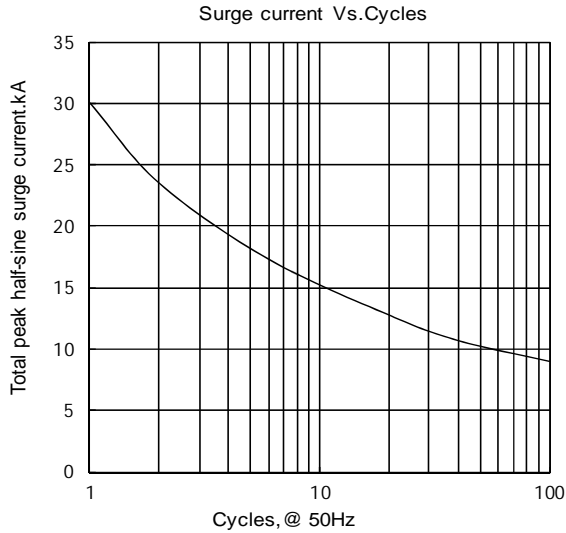

Fig. 7

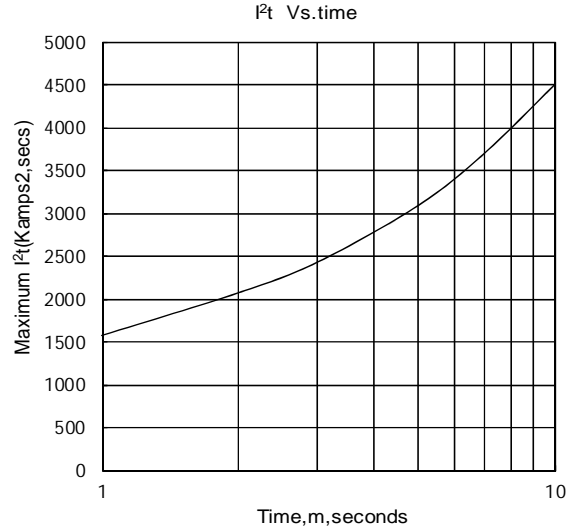

Fig. 8

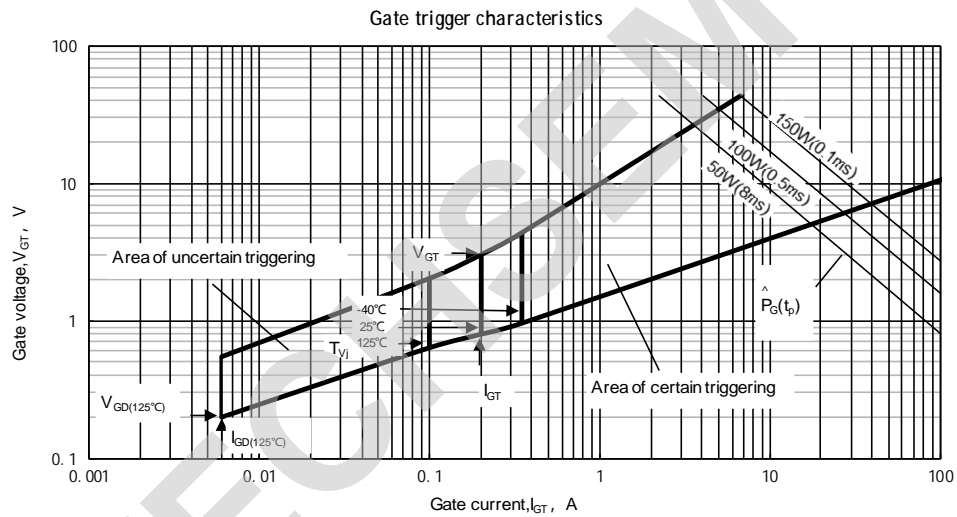
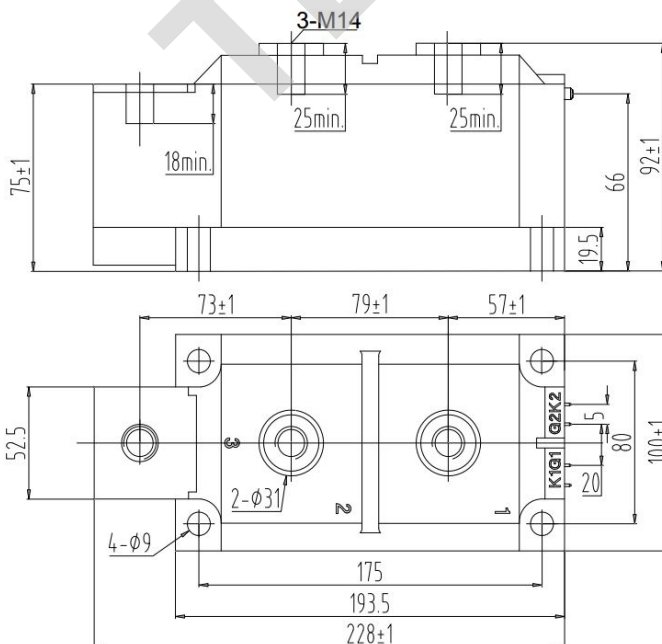
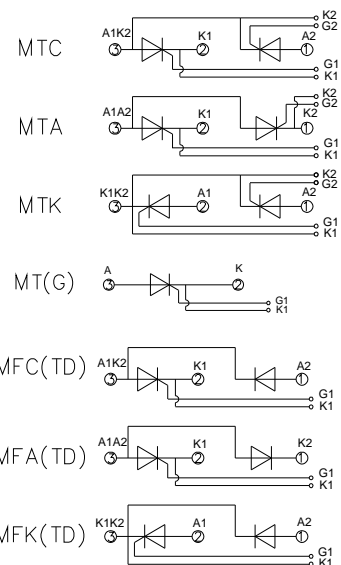

Fig. 9

Outline:



Unmarked dimensional tolerance: ±0.5mm



TECHSEM reserves the right to change specifications without notice.