

**Features**

- n Low forward voltage drop
- n High reverse voltage
- n Hermetic metal cases with ceramic insulators

Typical Applications

- n All purpose high power rectifier diodes
- n High power resistance welding equipment
- n Non-controllable and half-controllable rectifiers
- n Controlled rectifiers

Part No. H150ZPU-ZT140dT

I_{F(AV)}	6500 A
V_{RRM}	8100V 8300 V 8500 V

SYMBOL	CHARACTERISTIC	TEST CONDITIONS		T _J (°C)	VALUE			UNIT
					Min	Type	Max	
I _{F(AV)}	Mean forward current	180° half sine wave 50Hz Double side cooled,	T _C =100°C	150			6500	A
V _{RRM}	Repetitive peak reverse voltage	tp=10ms		150	8000		8500	V
I _{RRM}	Repetitive peak current	At V _{RRM}		150			500	mA
I _{FSM}	Surge forward current	10ms half sine wave V _R =0.6V _{RRM}		150			100	kA
I ² t	I ² t for fusing coordination						50000	10 ³ A ² s
V _{FO}	Threshold voltage			150			0.800	V
r _F	Forward slope resistance						0.125	mΩ
V _{FM}	Peak forward voltage	I _{FM} =5000A, F=140kHz		25			1.50	V
Q _{rr}	Recovery charge	I _{FM} =2000A, tp=4000μs, di/dt=-20A/μs, V _R =100V				14000		μC
R _{th(j-c)}	Thermal resistance Junction to case	At 180° sine double side cooled Clamping force 24kN					0.0028	°C/W
R _{th(c-h)}	Thermal resistance case to heat sink					0.0006		
F _m	Mounting force				165		190	kN
T _{vj}	Junction temperature				-40		150	°C
T _{stg}	Stored temperature				-40		160	°C
W _t	Weight					4000		g
Outline	ZT140dT							

Outline:

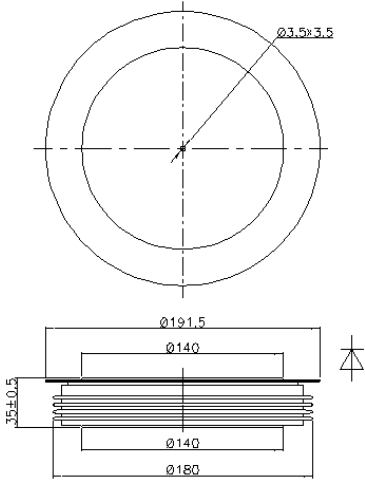

TECHSEM reserves the right to change specifications without notice.

TECHSEM