



Features:

- n Isolated mounting base 2500V~
- n Pressure contact technology with Increased power cycling capability
- n Space and weight saving

Typical Applications:

- n Inverter
- n Inductive heating
- n Chopper

V _{RRM} , V _{DRM}	Type & Outline	
600V	MKx75-06-216F3B	MHx75-06-216F3B
800V	MKx75-08-216F3B	MHx75-08-216F3B
1000V	MKx75-10-216F3B	MHx75-10-216F3B
1200V	MKx75-12-216F3B	MHx75-12-216F3B
1400V	MKx75-14-216F3B	MHx75-14-216F3B
1600V	MKx75-16-216F3B	MHx75-16-216F3B
1800V	MKx75-18-216F3B	MHx75-18-216F3B
1800V	MK75-18-216F3BG	

MKx stands for any type of MKC, MKA, MKK

SYMBOL	CHARACTERISTIC	TEST CONDITIONS	T _i (°C)	VALUE			UNIT	
				Min	Type	Max		
I _{T(AV)}	Mean on-state current	180° half sine wave 50Hz Single side cooled, T _c =85°C	125			75	A	
I _{T(RMS)}	RMS on-state current					118	A	
I _{DRM} I _{RRM}	Repetitive peak current	at V _{DRM} at V _{RRM}	125			30	mA	
I _{TSM}	Surge on-state current	10ms half sine wave V _R =60%V _{RRM}	125			1.6	kA	
I ² t	I ² t for fusing coordination					13	10 ³ A ² s	
V _{TO}	Threshold voltage		125			1.50	V	
r _T	On-state slope resistance					4.00	mW	
V _{TM}	Peak on-state voltage	I _{TM} =225A	25			2.53	V	
dv/dt	Critical rate of rise of off-state voltage	V _{DM} =67%V _{DRM}	125			800	V/μs	
di/dt	Critical rate of rise of on-state current	Gate source 1.5A t _r ≤0.5μs Repetitive	125			200	A/μs	
t _q	Circuit commutated turn-off time	I _{TM} =200A, t _p =4000μs, V _R =100V dv/dt=30V/μs, di/dt=-20A/μs	125	20		40	μs	
			25	6		16	μs	
I _{GT}	Gate trigger current	V _A =12V, I _A =1A	25			30	mA	
V _{GT}	Gate trigger voltage					0.8	2.5	V
I _H	Holding current					20	200	mA
I _L	Latching current						1000	mA
V _{GD}	Non-trigger gate voltage	V _{DM} = 67%V _{DRM}	125			0.2	V	
R _{th(j-c)}	Thermal resistance Junction to case	Single side cooled per chip				0.20	°C /W	
R _{th(c-h)}	Thermal resistance case to heatsink	Single side cooled per chip				0.04	°C /W	
V _{iso}	Isolation voltage	50Hz, R.M.S, t=1min, I _{iso} :1mA(MAX)		2500			V	
F _m	Terminal connection torque(M6)			4.5		6.0	N·m	
	Mounting torque(M6)			4.5		6.0	N·m	
T _{vj}	Junction temperature			-40		125	°C	
T _{stg}	Stored temperature			-40		125	°C	
W _t	Weight				320		g	
Outline	216F3B							

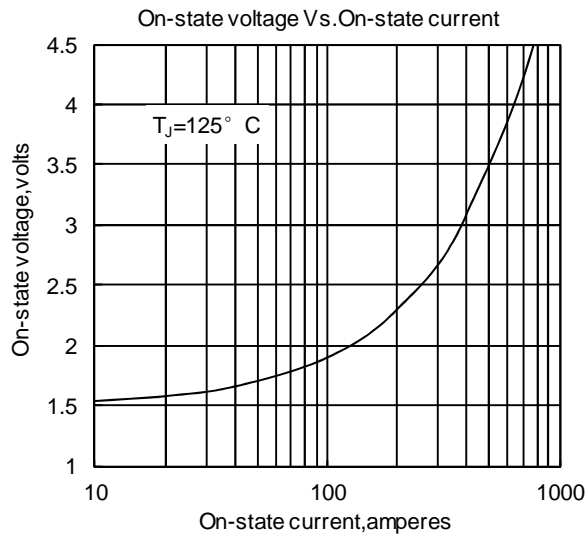

Fig.1

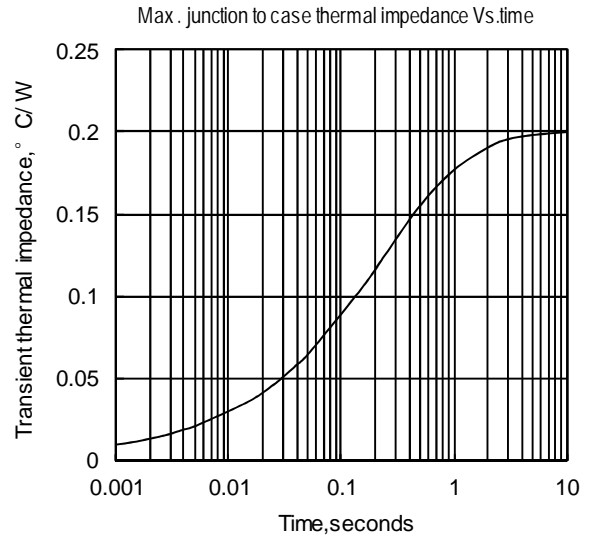

Fig.2

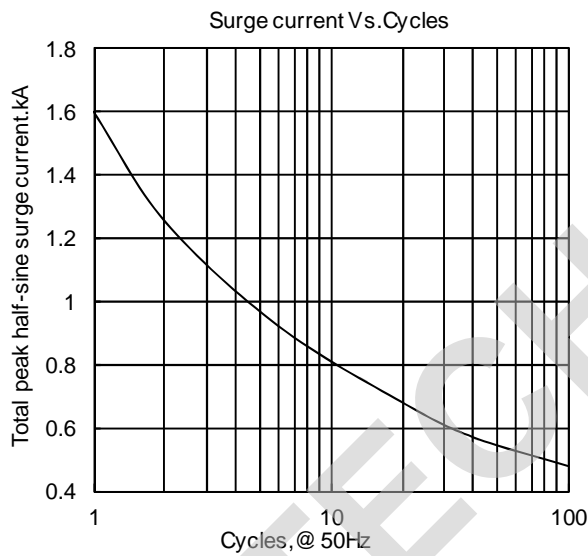

Fig.3

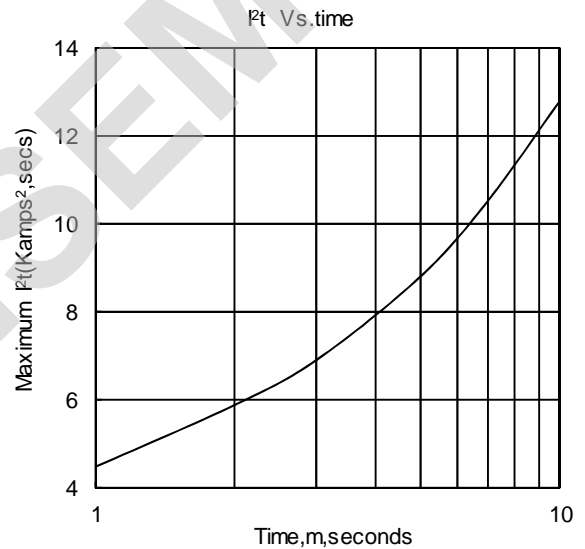

Fig.4

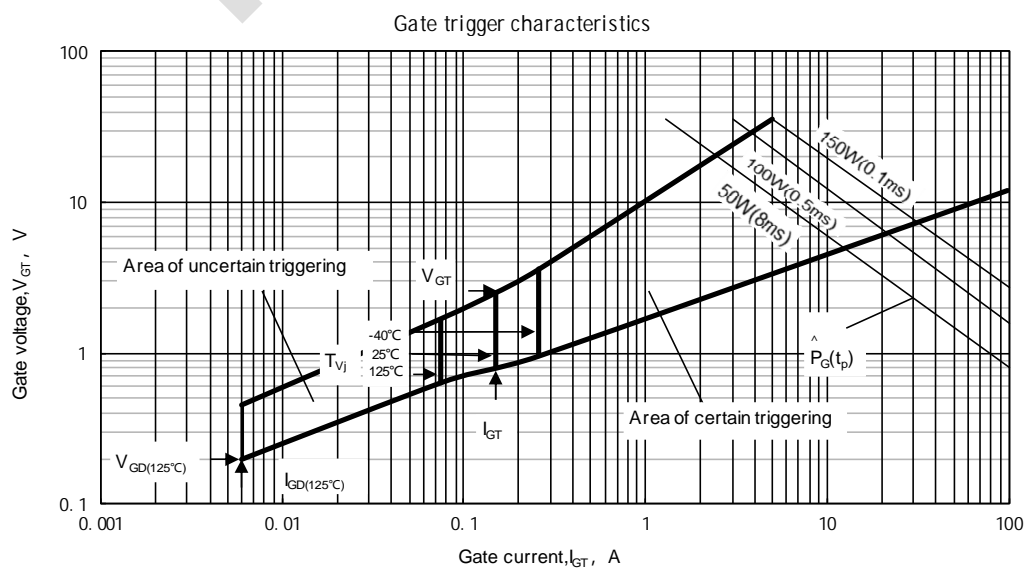
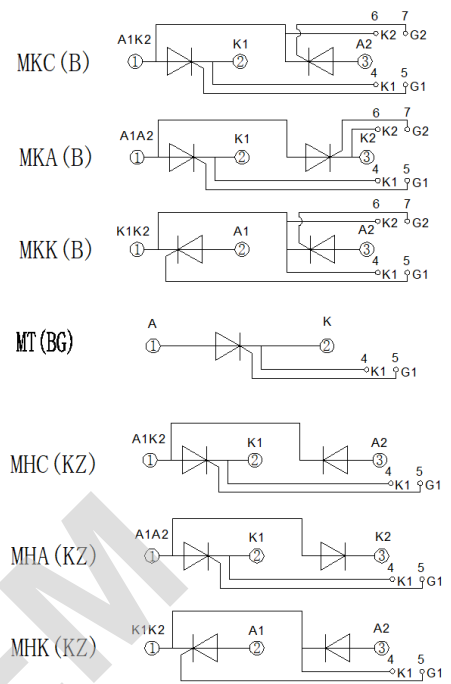
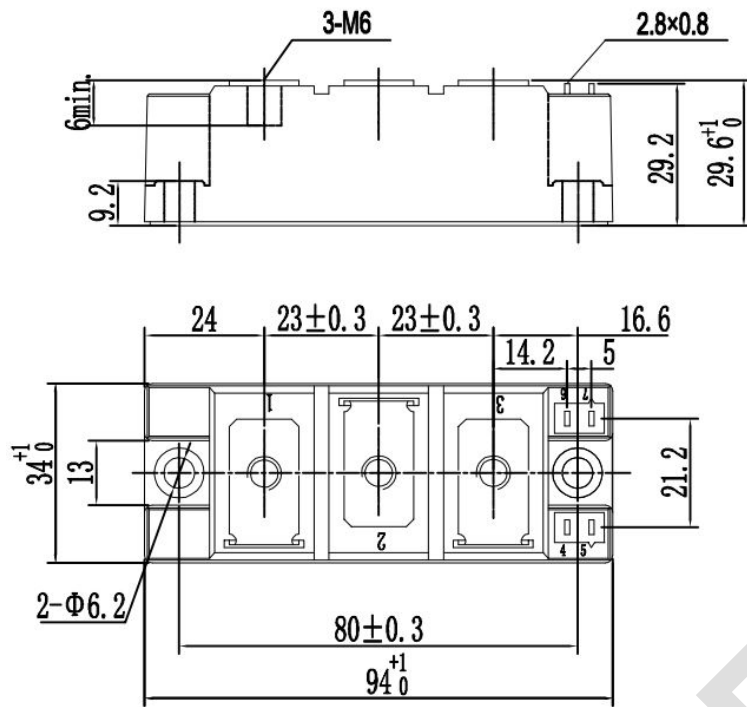

Fig.5

Outline:



Unmarked dimensional tolerance: ± 0.5 mm
TECHSEM reserves the right to change specifications without notice.