

Features

- n Low forward voltage drop
- n High reverse voltage
- n Hermetic metal cases with ceramic insulators

Typical Applications

- n All purpose high power rectifier diodes
- n High power resistance welding equipment
- n Non-controllable and half-controllable rectifiers
- n Controlled rectifiers

Part No. Y38ZPB-ZT33cT		
I_{F(AV)}	1700A	
V_{RRM}	200V	400V
	600V	800V
	1000V	1200V
	1400V	

SYMBOL	CHARACTERISTIC	TEST CONDITIONS		T _J (°C)	VALUE			UNIT
					Min	Type	Max	
I _{F(AV)}	Mean forward current	180° half sine wave 50Hz Double side cooled,	T _C =85°C	190			1700	A
V _{RRM}	Repetitive peak reverse voltage	tp=10ms		190	200		1400	V
I _{RRM}	Repetitive peak current	at V _{RRM}		190			40	mA
I _{FSM}	Surge forward current	10ms half sine wave		190			18	kA
I ² t	I ² t for fusing coordination	V _R =0.6V _{RRM}						1620
V _{FO}	Threshold voltage			190			0.81	V
r _F	Forward slope resistance							0.23
V _{FM}	Peak forward voltage	I _{FM} =2400A, F=15kN		25			2.0	V
Q _{rr}	Recovery charge	I _{FM} =1000A, tp=4000μs, di/dt=-20A/μs, V _R =100V		190		1900		μC
R _{th(j-c)}	Thermal resistance Junction to case	At 180° sine double side cooled Clamping force 15.0kN					0.035	°C /W
R _{th(c-h)}	Thermal resistance case to heat sink						0.008	
F _m	Mounting force				10		20	kN
T _{vj}	Junction temperature				-40		190	°C
T _{stg}	Stored temperature				-40		190	°C
W _t	Weight					240		g
Outline	ZT33cT							

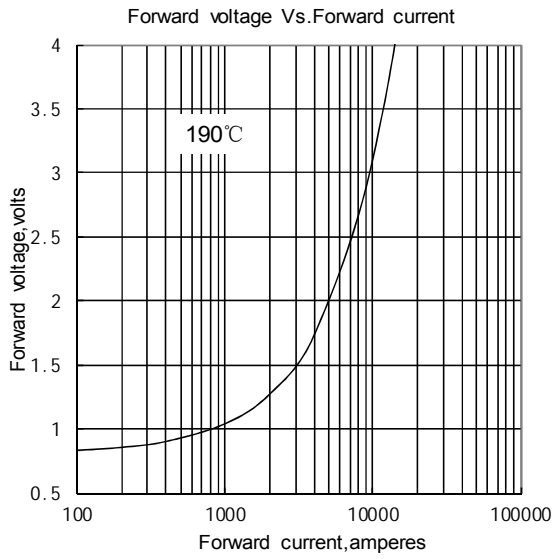

Fig.1

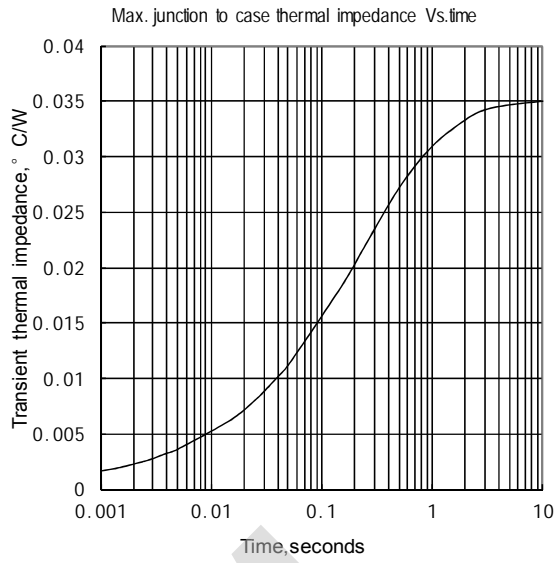

Fig.2

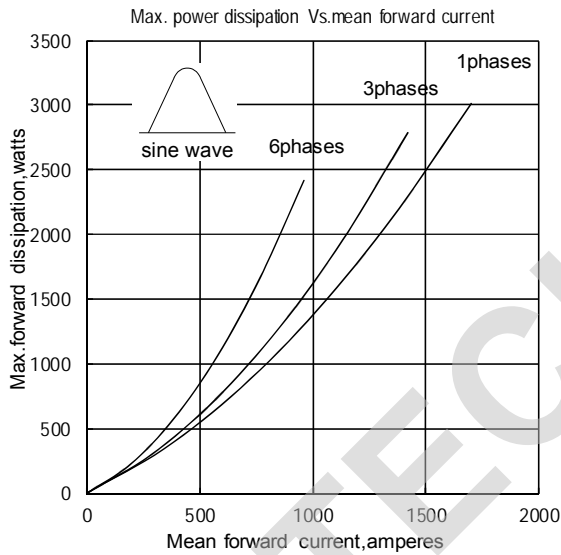

Fig.3

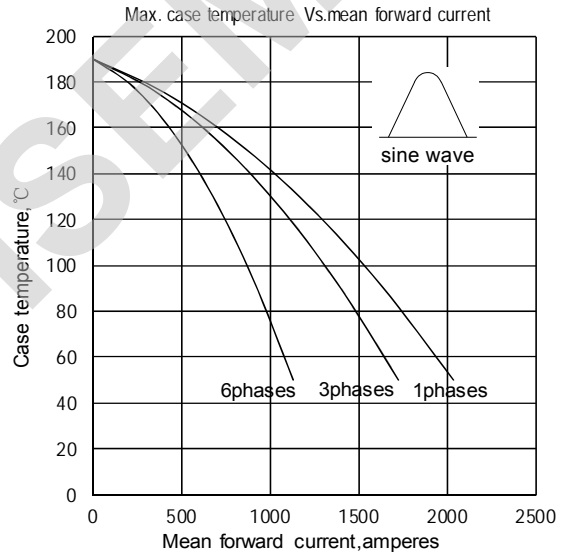

Fig.4

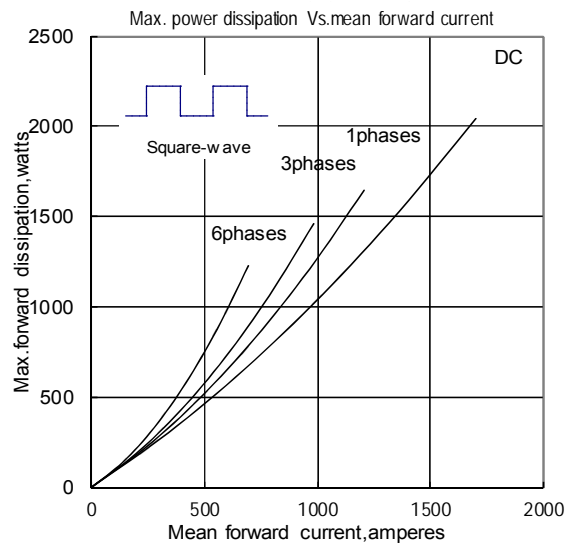

Fig.5

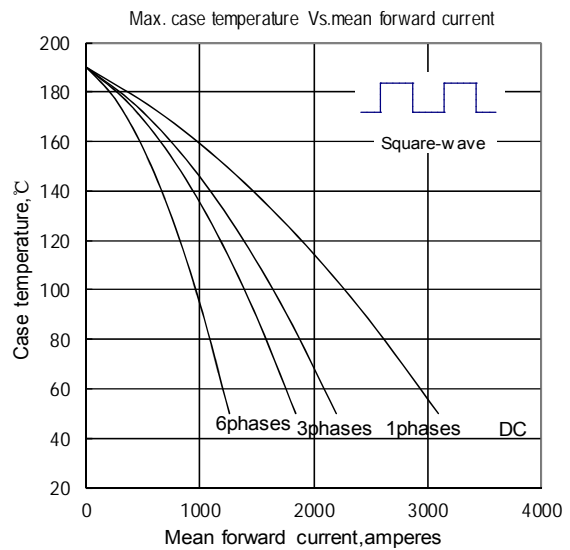

Fig.6

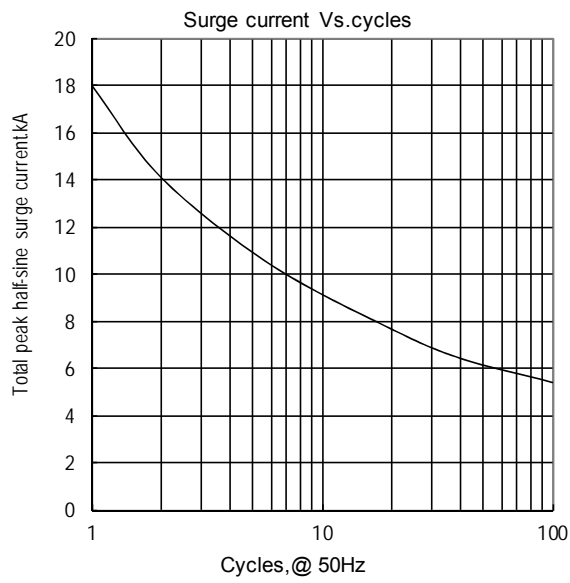

Fig.7

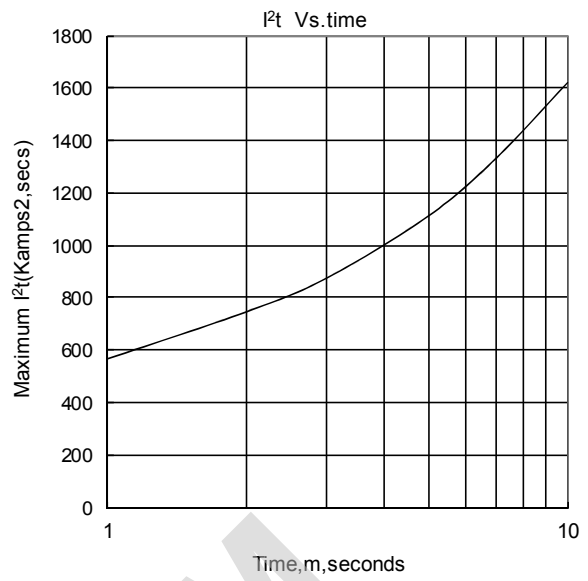
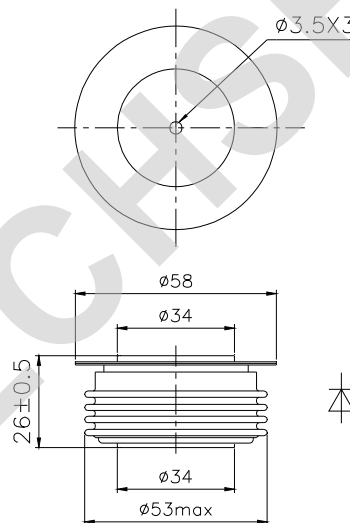

Fig.8

Outline:



TECHSEM reserves the right to change specifications without notice.