**Features :**

- n Isolated mounting base 2500V
- n Solder joint technology with Increased power cycling capability
- n Space and weight savings

Typical Applications :

- n DC Power supplies for equipments.
- n DC supply for PWM inverter
- n Inverter Welder

V_{RRM}	Type & Outline
600V	MDQ75-06-232H5
800V	MDQ75-08-232H5
1000V	MDQ75-10-232H5
1200V	MDQ75-12-232H5
1400V	MDQ75-14-232H5
1600V	MDQ75-16-232H5
1800V	MDQ75-18-232H5

SYMBOL	CHARACTERISTIC	TEST CONDITIONS	$T_j(^{\circ}C)$	VALUE			UNIT
				Min	Type	Max	
I_o	DC output current	Single-phase full wave rectifying circuit, $T_c=100^{\circ}C$	150			75	A
I_{RRM}	Repetitive peak current	at V_{RRM}	150			8	mA
I_{FSM}	Surge forward current	10ms half sine wave $V_R=0$	150			0.6	kA
I^2t	I^2t for fusing coordination					1.8	A^2s*10^3
V_{FO}	Threshold voltage		150			0.7	V
r_F	Forward slop resistance					4.2	m
V_{FM}	Peak forward voltage	$I_{FM}=120A$	25			1.38	V
$R_{th(j-c)}$	Thermal resistance Junction to case	Single side cooled, per total				0.20	$^{\circ}C/W$
$R_{th(c-h)}$	Thermal resistance case to heatsink	Single side cooled, per total				0.07	$^{\circ}C/W$
V_{iso}	Isolation voltage	50Hz,R.M.S, $t=1min, I_{iso}:1mA(max)$		2500			V
F_m	Terminal connection torque(M5)				4.0		N·m
	Mounting torque(M5)				4.0		N·m
T_{vj}	Junction temperature			-40		150	$^{\circ}C$
T_{stg}	Stored temperature			-40		125	$^{\circ}C$
W_t	Weight				120		g
Outline	232H5						

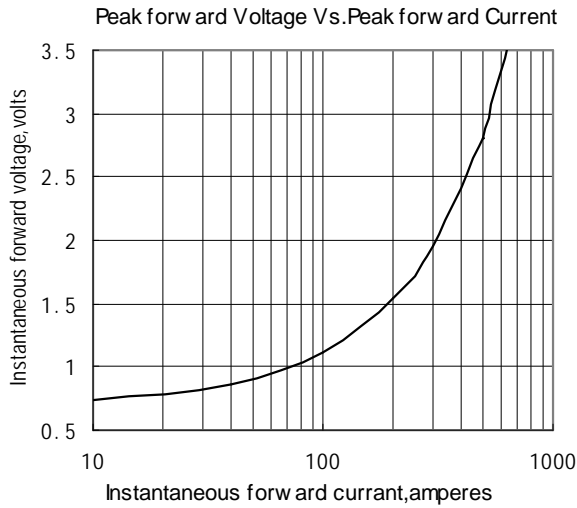

Fig.1

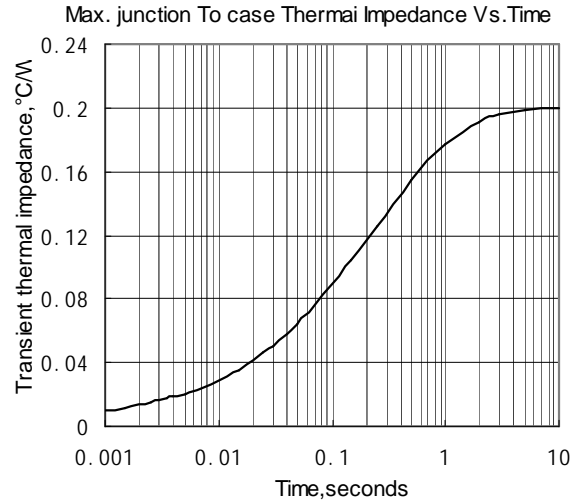

Fig.2

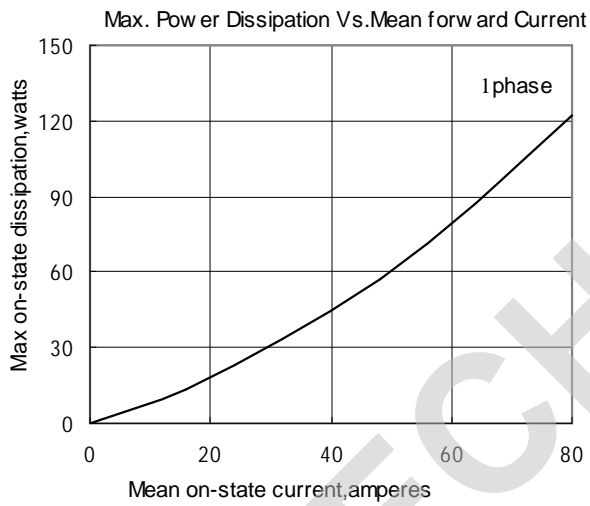

Fig.3

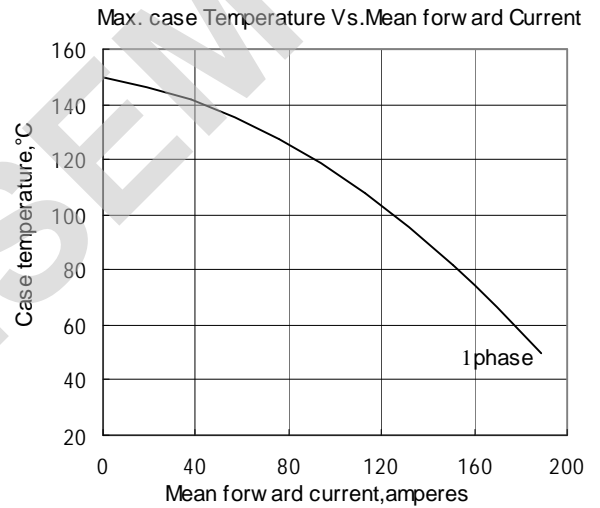

Fig.4

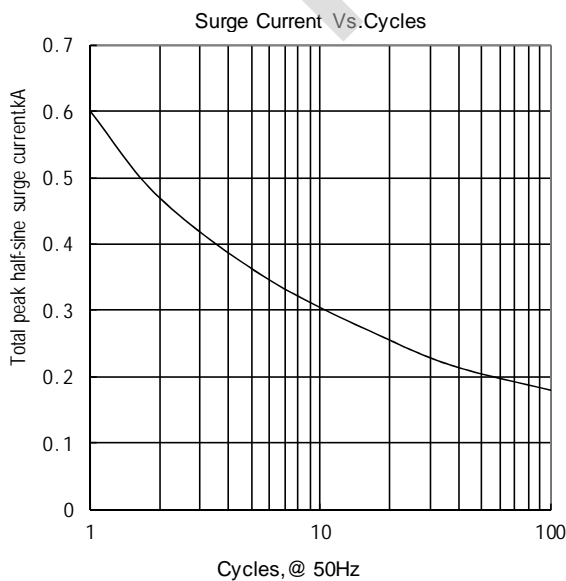

Fig.5

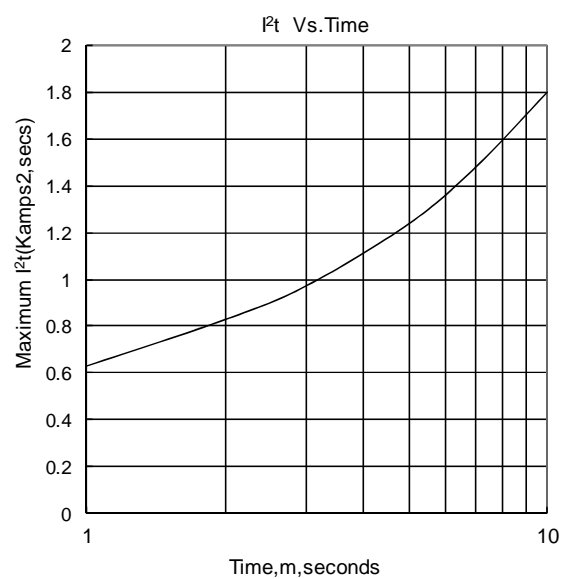
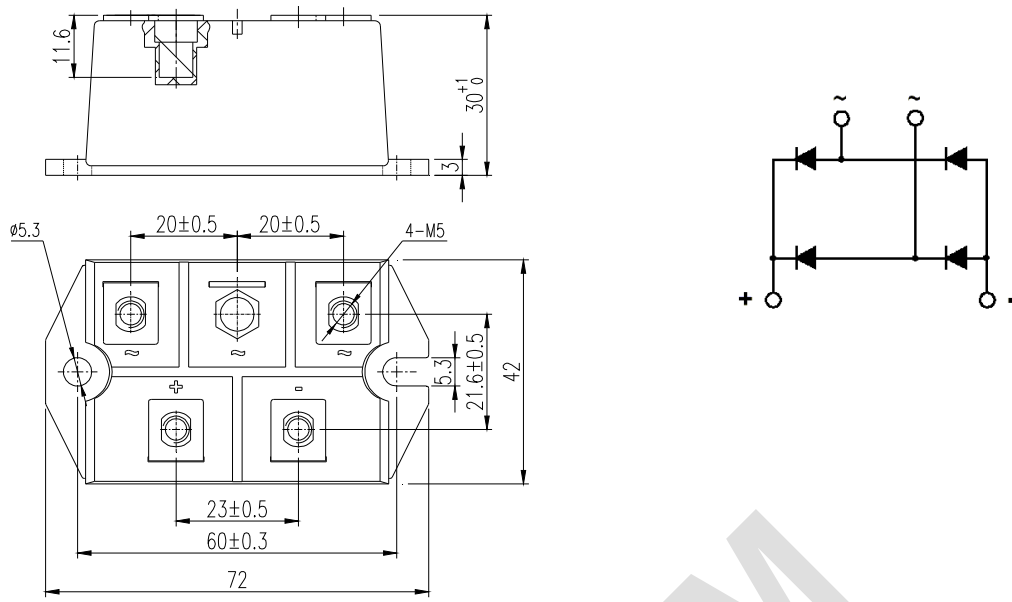

Fig.6

Outline:



Unmarked dimensional tolerance: $\pm 0.5\text{mm}$

TECHSEM