

Features:

- n Non-isolated. Mounting base as common anode cathode terminal.
- n Pressure contact technology with increased power cycling capability
- n Low forward voltage drop

Typical Applications:

- n Welding Power Supply.
- n Various Dc power supplies.

V _{RRM}	Type & Outline
800V	MDx100-08-213F4
1000V	MDx100-10-213F4
1200V	MDx100-12-213F4
1400V	MDx100-14-213F4
1600V	MDx100-16-213F4
1800V	MDx100-18-213F4

MDx stands for any type of **MDG, MDY**

SYMBOL	CHARACTERISTIC	TEST CONDITIONS	T _j (°C)	VALUE			UNIT
				Min	Type	Max	
I _{F(AV)}	Mean forward current	180° half sine wave 50Hz Single side cooled, T _c =100°C	150			100	A
I _{F(RMS)}	RMS forward current					157	A
I _{RRM}	Repetitive peak current	at V _{RRM}	150			12	mA
I _{FSM}	Surge forward current	V _R =60%V _{RRM} , t=10ms half sine	150			2.8	kA
I ² t	I ² t for fusing coordination					39	10 ³ A ² s
V _{FO}	Threshold voltage		150			0.80	V
r _F	Forward slope resistance					2.13	mΩ
V _{FM}	Peak forward voltage	I _{FM} =300A	25			1.57	V
R _{th(j-c)}	Thermal resistance Junction to case	At 180° sine. Single side cooled				0.38	°C/W
R _{th(c-h)}	Thermal resistance case to heatsink	At 180° sine. Single side cooled				0.10	°C/W
F _m	Terminal connection torque(M6)			4.5		6.0	N·m
	Mounting torque(M6)			4.5		6.0	N·m
T _{vj}	Junction temperature			-40		150	°C
T _{stg}	Stored temperature			-40		125	°C
W _t	Weight					280	g
Outline	213F4						

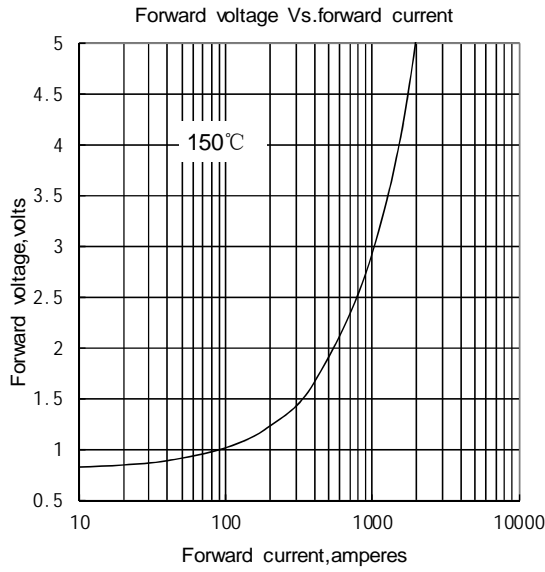

Fig.1

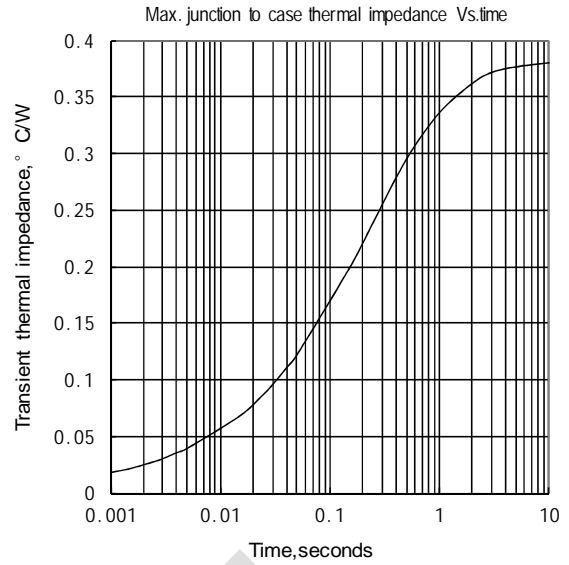

Fig.2

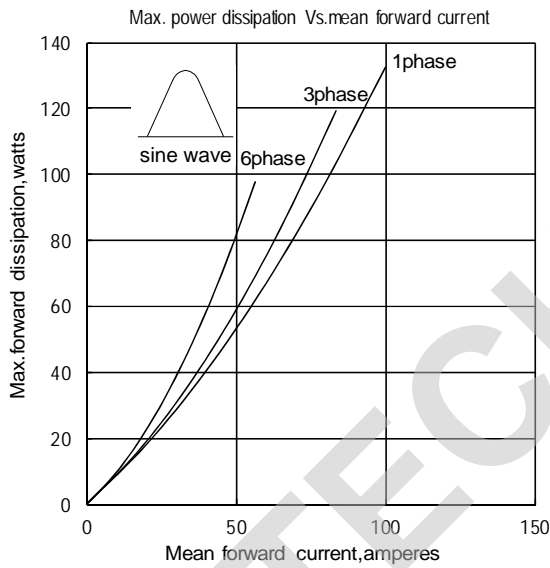

Fig.3

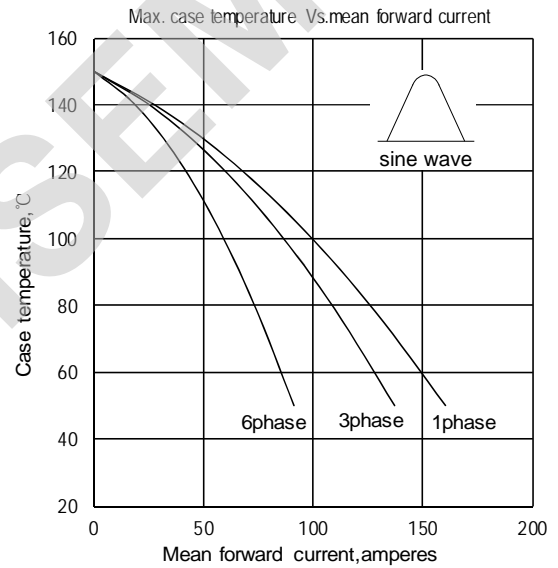

Fig.4

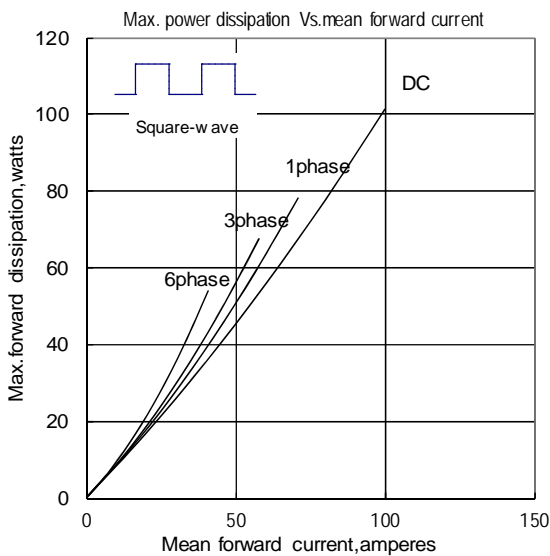

Fig.5

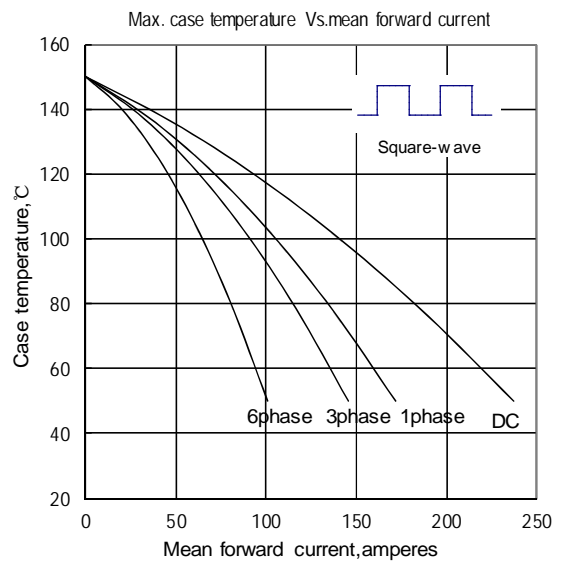

Fig.6

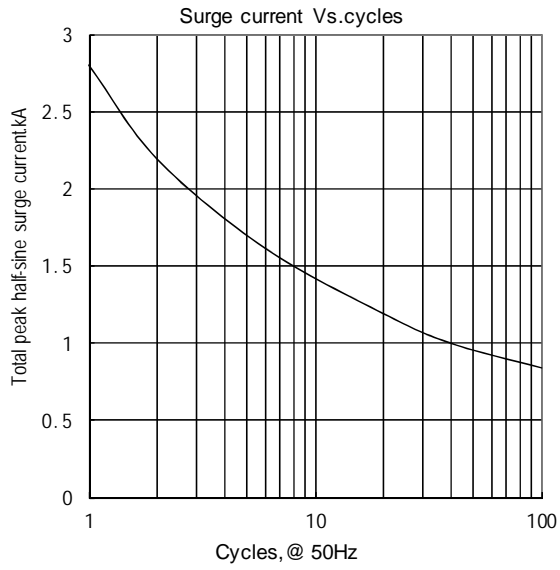

Fig.7

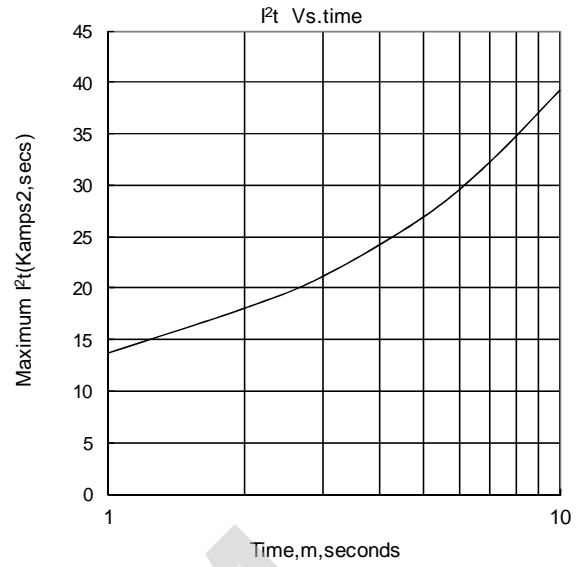
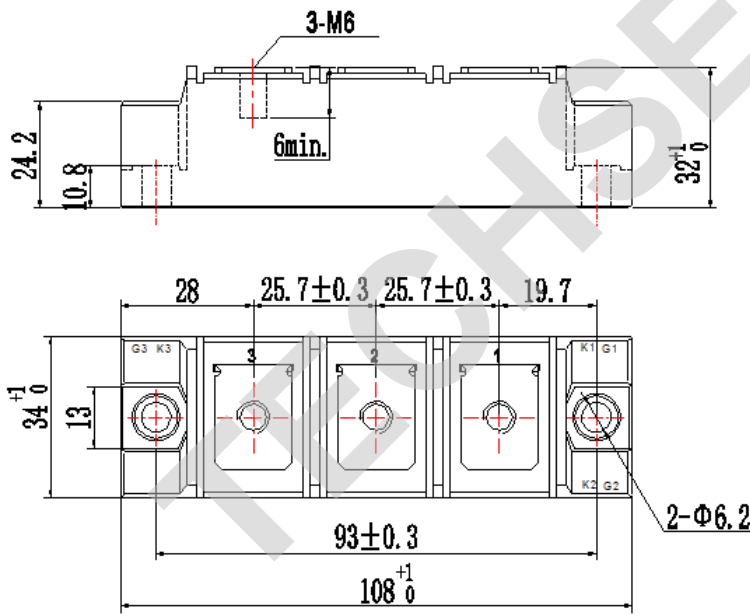
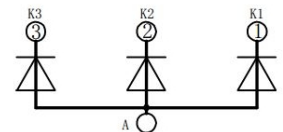

Fig.8

Outline:



MDG



MDY

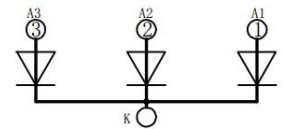

Unmarked dimensional tolerance: ±0.5mm